

# Chapter 7

## Network Flow

Slides by Kevin Wayne.  
Copyright © 2005 Pearson-Addison Wesley.  
All rights reserved.

## 7.5 Bipartite Matching

---

# Matching

## Matching.

- Input: undirected graph  $G = (V, E)$ .
- $M \subseteq E$  is a **matching** if each node appears in at most edge in  $M$ .
- Max matching: find a max cardinality matching.

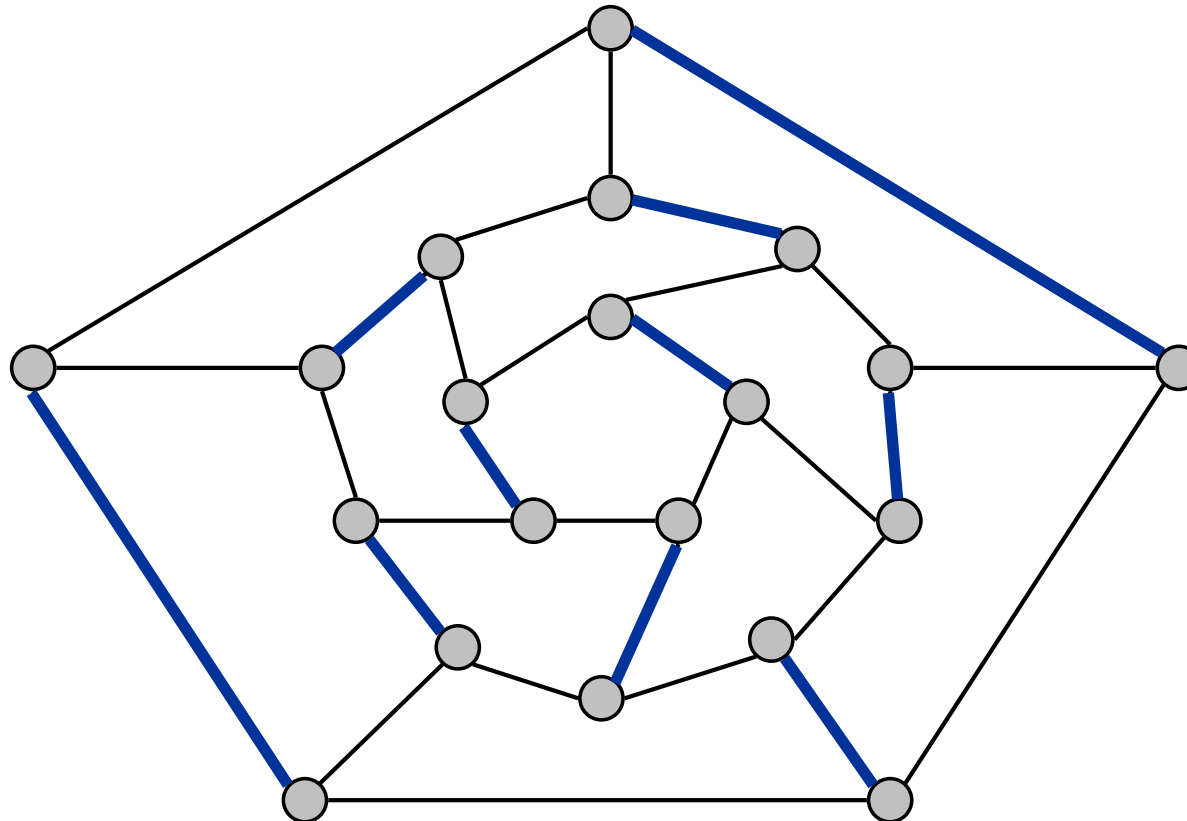

# Bipartite Matching

## Bipartite matching.

- Input: undirected, **bipartite** graph  $G = (L \cup R, E)$ .
- $M \subseteq E$  is a **matching** if each node appears in at most edge in  $M$ .
- Max matching: find a max cardinality matching.

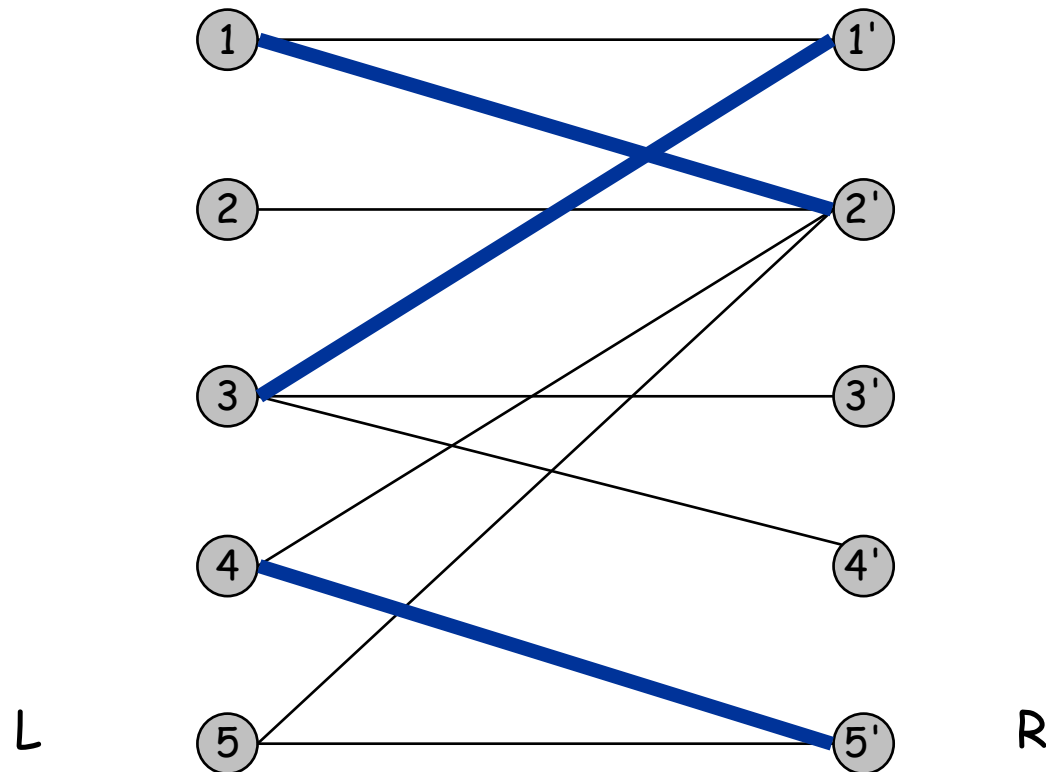

matching  
1-2', 3-1', 4-5'

# Bipartite Matching

## Bipartite matching.

- Input: undirected, **bipartite** graph  $G = (L \cup R, E)$ .
- $M \subseteq E$  is a **matching** if each node appears in at most edge in  $M$ .
- Max matching: find a max cardinality matching.

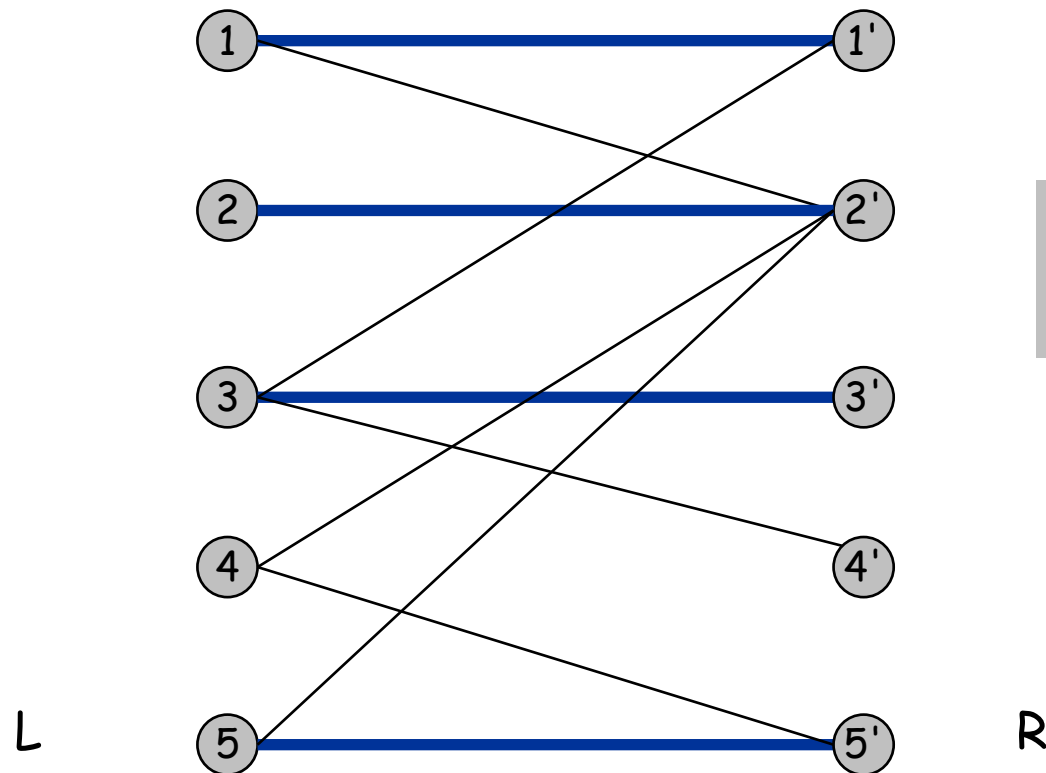

max matching  
1-1', 2-2', 3-3' 4-4'

# Bipartite Matching

## Max flow formulation.

- Create digraph  $G' = (L \cup R \cup \{s, t\}, E')$ .
- Direct all edges from  $L$  to  $R$ , and assign infinite (or unit) capacity.
- Add source  $s$ , and unit capacity edges from  $s$  to each node in  $L$ .
- Add sink  $t$ , and unit capacity edges from each node in  $R$  to  $t$ .

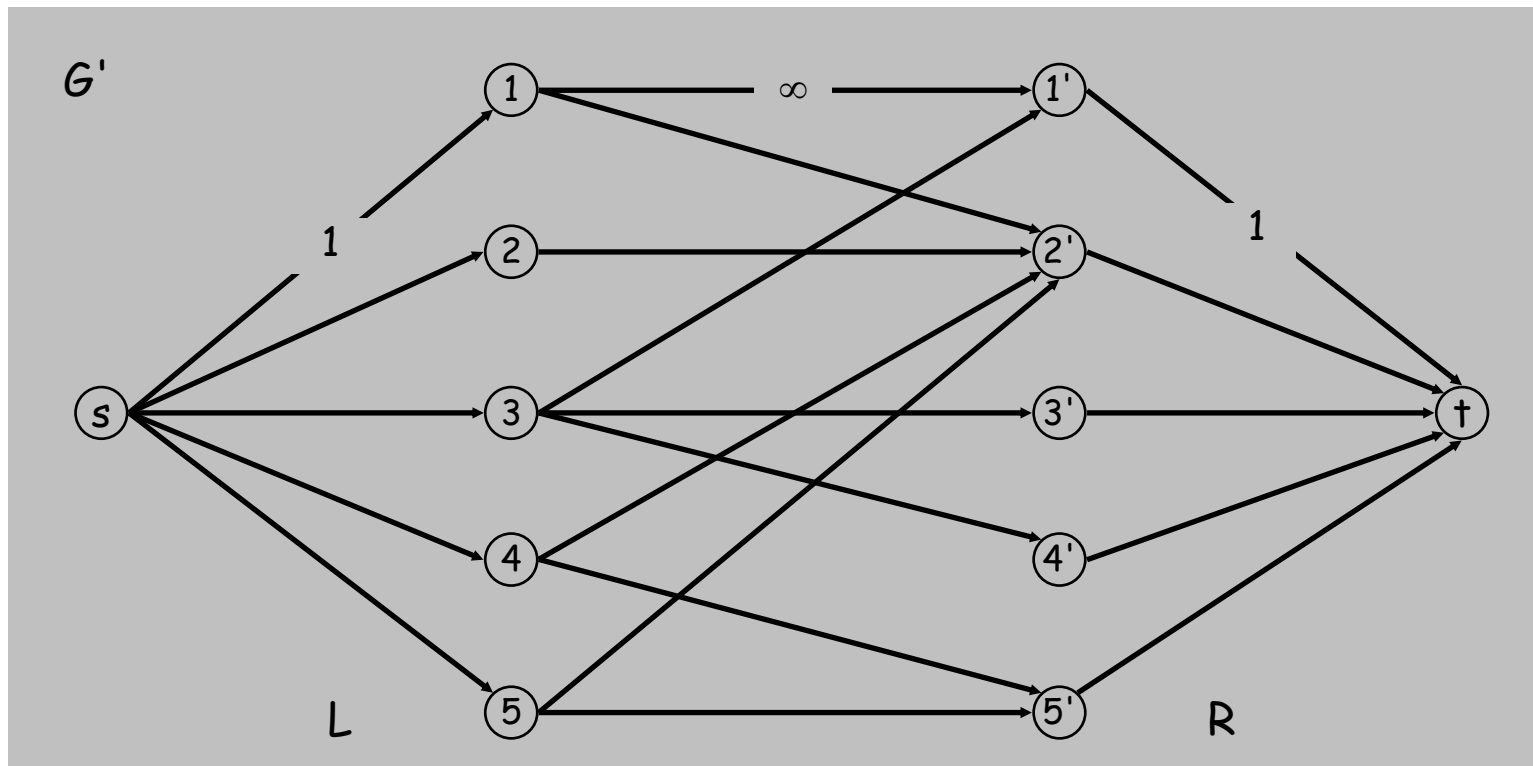

# Bipartite Matching: Proof of Correctness

**Theorem.** Max cardinality matching in  $G$  = value of max flow in  $G'$ .

**Pf.**  $\leq$

- Given max matching  $M$  of cardinality  $k$ .
- Consider flow  $f$  that sends 1 unit along each of  $k$  paths.
- $f$  is a flow, and has cardinality  $k$ .

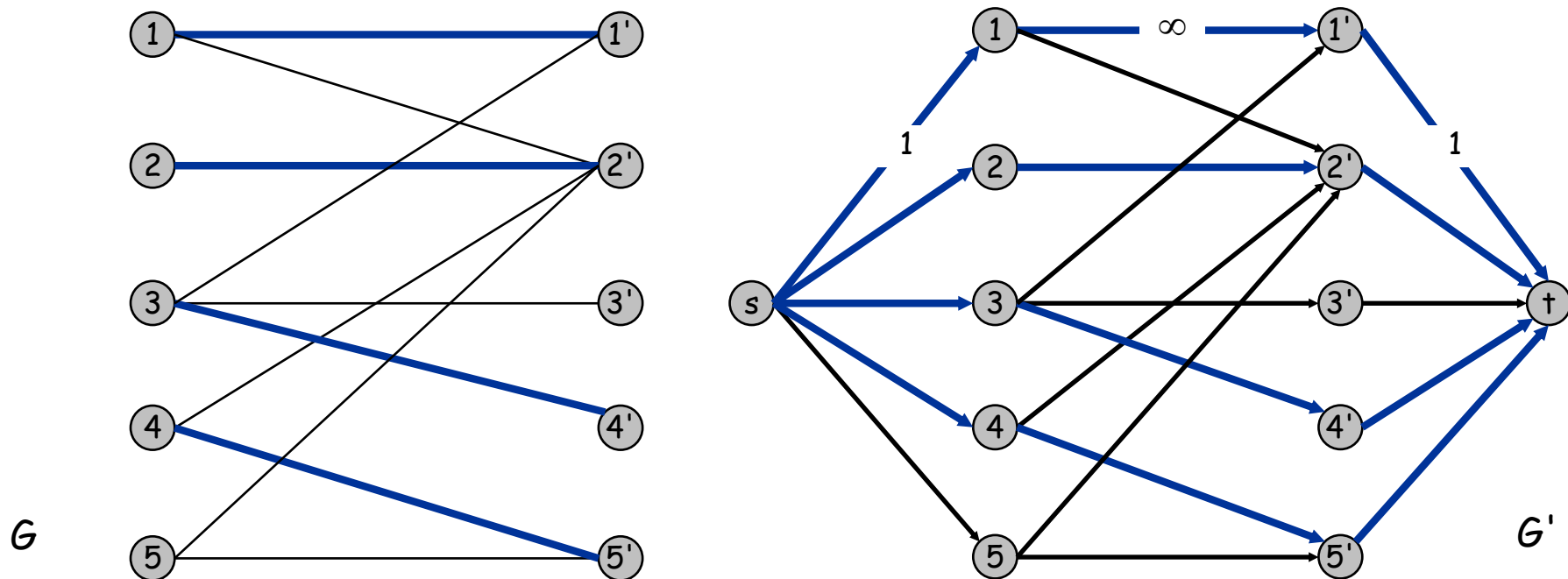

# Bipartite Matching: Proof of Correctness

**Theorem.** Max cardinality matching in  $G$  = value of max flow in  $G'$ .

**Pf.**  $\geq$

- Let  $f$  be a max flow in  $G'$  of value  $k$ .
- Integrality theorem  $\Rightarrow$   $k$  is integral and can assume  $f$  is 0-1.
- Consider  $M$  = set of edges from  $L$  to  $R$  with  $f(e) = 1$ .
  - each node in  $L$  and  $R$  participates in at most one edge in  $M$
  - $|M| = k$ : consider cut  $(L \cup s, R \cup t)$  .

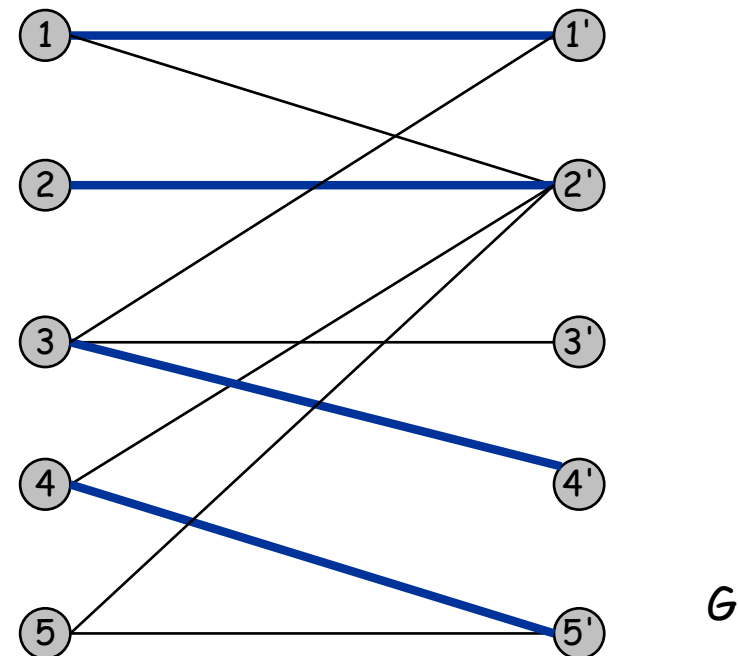
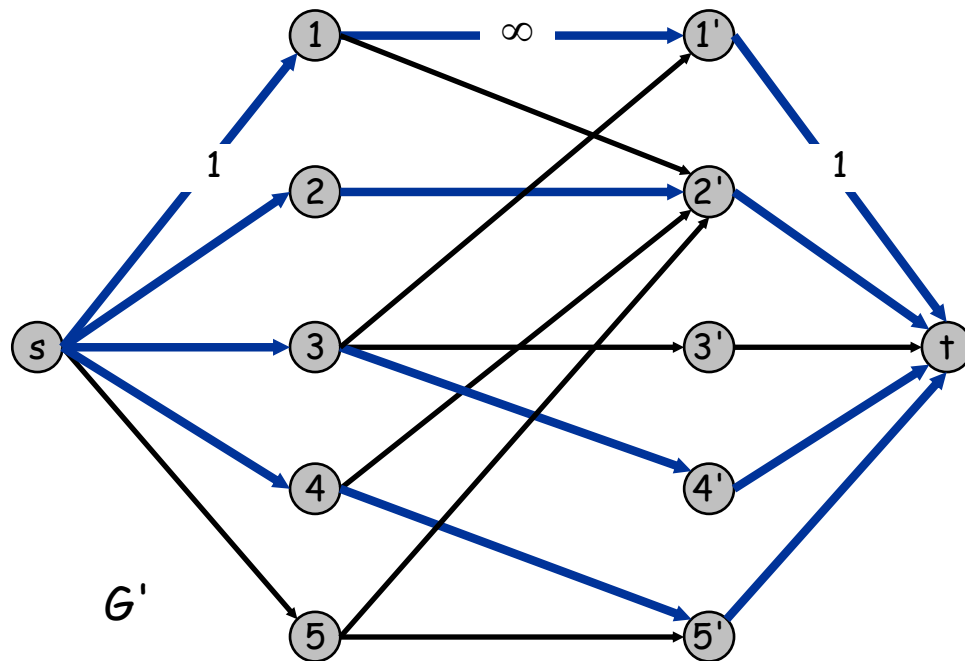



# Perfect Matching

**Def.** A matching  $M \subseteq E$  is **perfect** if each node appears in exactly one edge in  $M$ .

**Q.** When does a bipartite graph have a perfect matching?

Structure of bipartite graphs with perfect matchings.

- Clearly we must have  $|L| = |R|$ .
- What other conditions are necessary?
- What conditions are sufficient?

# Perfect Matching

**Notation.** Let  $S$  be a subset of nodes, and let  $N(S)$  be the set of nodes adjacent to nodes in  $S$ .

**Observation.** If a bipartite graph  $G = (L \cup R, E)$ , has a perfect matching, then  $|N(S)| \geq |S|$  for all subsets  $S \subseteq L$ .

**Pf.** Each node in  $S$  has to be matched to a different node in  $N(S)$ .

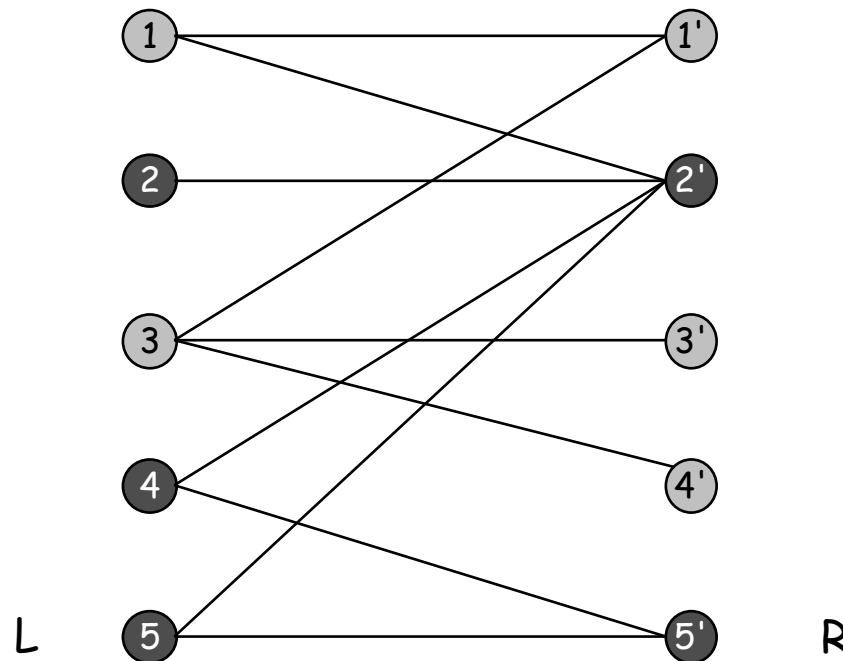

No perfect matching:

$S = \{ 2, 4, 5 \}$

$N(S) = \{ 2', 5' \}$ .

# Marriage Theorem

**Marriage Theorem.** [Frobenius 1917, Hall 1935] Let  $G = (L \cup R, E)$  be a bipartite graph with  $|L| = |R|$ . Then,  $G$  has a perfect matching iff  $|N(S)| \geq |S|$  for all subsets  $S \subseteq L$ .

**Pf.**  $\Rightarrow$  This was the previous observation.

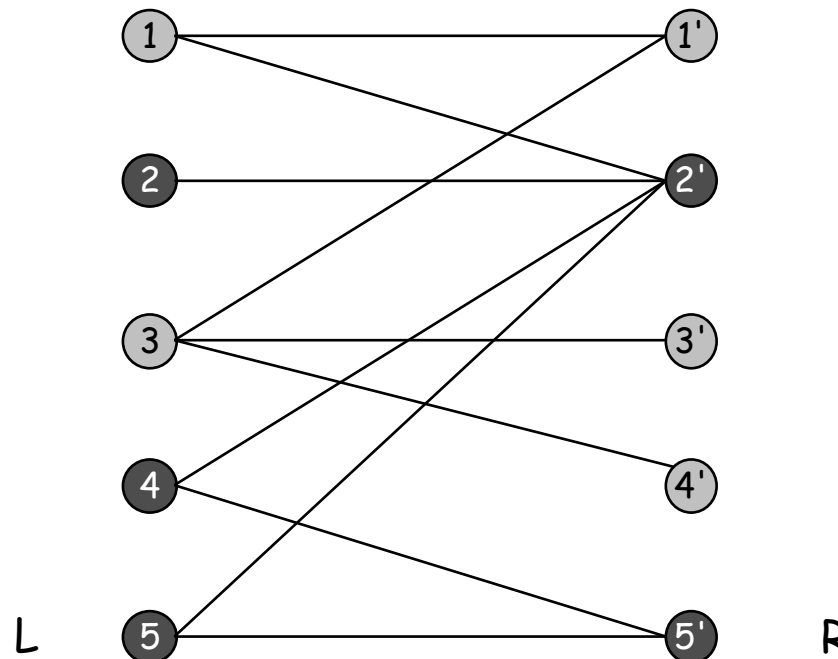

No perfect matching:

$$S = \{ 2, 4, 5 \}$$

$$N(S) = \{ 2', 5' \}.$$

## 7.6 Disjoint Paths

---

## Edge Disjoint Paths

**Disjoint path problem.** Given a digraph  $G = (V, E)$  and two nodes  $s$  and  $t$ , find the max number of edge-disjoint  $s$ - $t$  paths.

**Def.** Two paths are **edge-disjoint** if they have no edge in common.

**Ex:** communication networks.

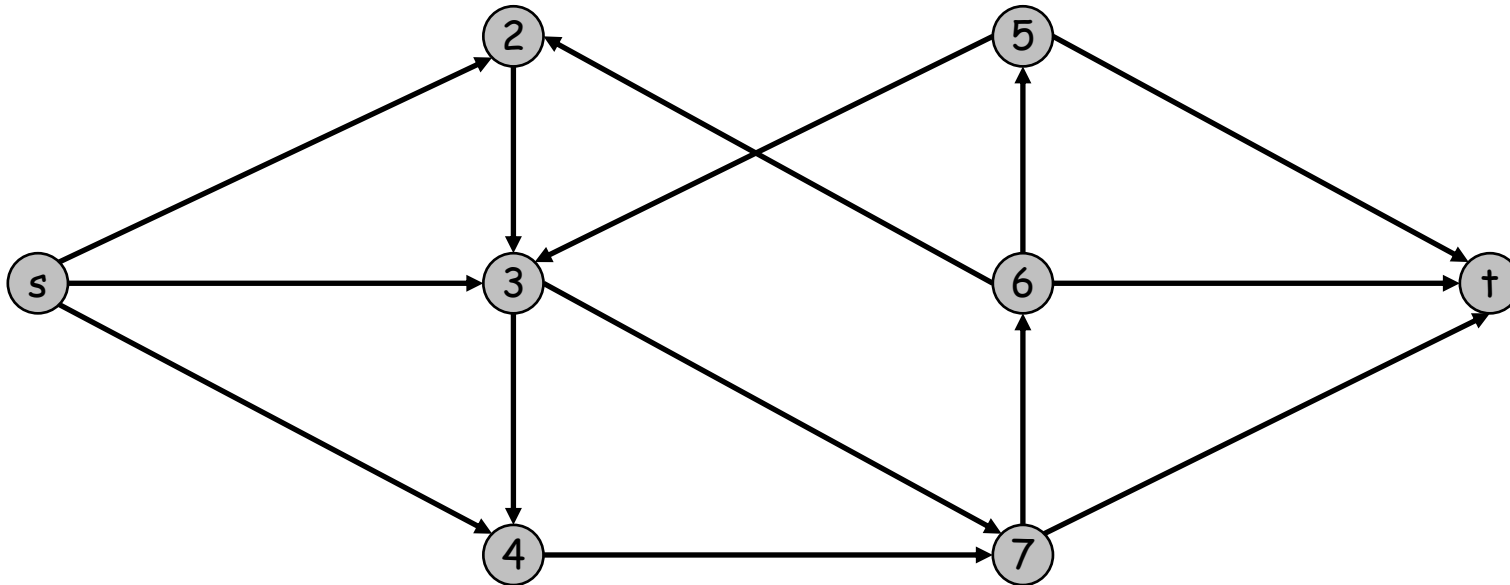

## Edge Disjoint Paths

**Disjoint path problem.** Given a digraph  $G = (V, E)$  and two nodes  $s$  and  $t$ , find the max number of edge-disjoint  $s$ - $t$  paths.

**Def.** Two paths are **edge-disjoint** if they have no edge in common.

**Ex:** communication networks.

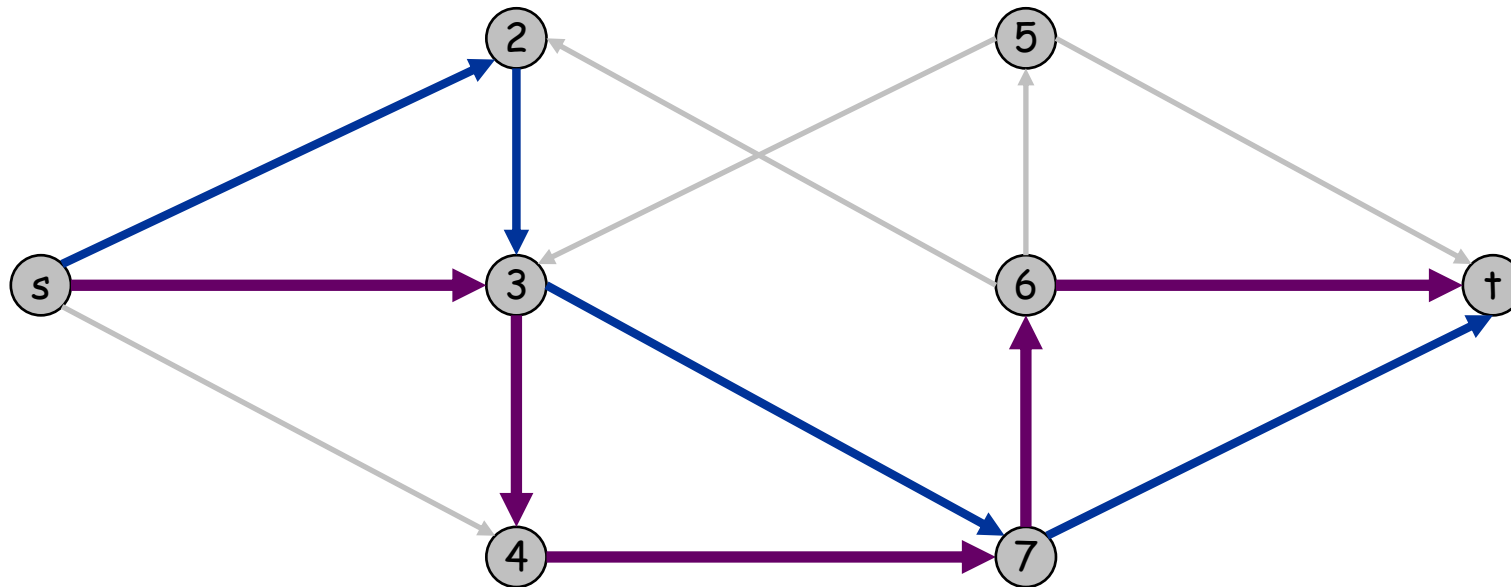

## Edge Disjoint Paths

Max flow formulation: assign unit capacity to every edge.

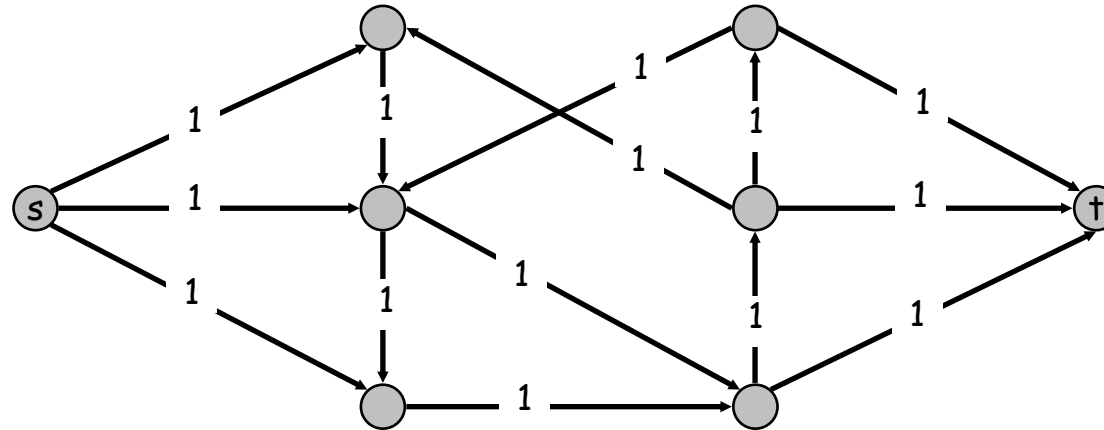

**Theorem.** Max number edge-disjoint  $s$ - $t$  paths equals max flow value.

**Pf.**  $\leq$

- Suppose there are  $k$  edge-disjoint paths  $P_1, \dots, P_k$ .
- Set  $f(e) = 1$  if  $e$  participates in some path  $P_i$ ; else set  $f(e) = 0$ .
- Since paths are edge-disjoint,  $f$  is a flow of value  $k$ . ▪

# Edge Disjoint Paths

Max flow formulation: assign unit capacity to every edge.

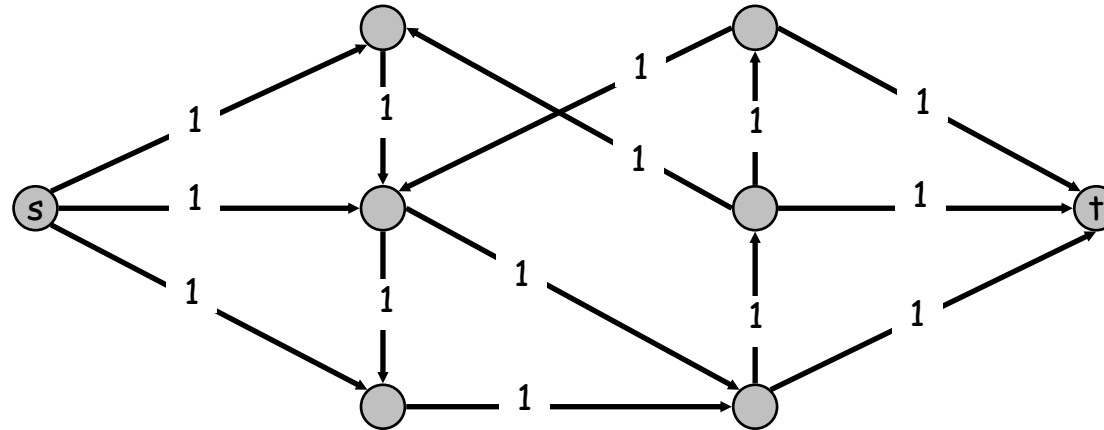

**Theorem.** Max number edge-disjoint s-t paths equals max flow value.

**Pf.**  $\geq$

- Suppose max flow value is  $k$ .
- Integrality theorem  $\Rightarrow$  there exists 0-1 flow  $f$  of value  $k$ .
- Consider edge  $(s, u)$  with  $f(s, u) = 1$ .
  - by conservation, there exists an edge  $(u, v)$  with  $f(u, v) = 1$
  - continue until reach  $t$ , always choosing a new edge
- Produces  $k$  (not necessarily simple) edge-disjoint paths. ▪

↙ can eliminate cycles to get simple paths if desired



# Network Connectivity

**Network connectivity.** Given a digraph  $G = (V, E)$  and two nodes  $s$  and  $t$ , find min number of edges whose removal disconnects  $t$  from  $s$ .

**Def.** A set of edges  $F \subseteq E$  **disconnects  $t$  from  $s$**  if all  $s$ - $t$  paths uses at least on edge in  $F$ .

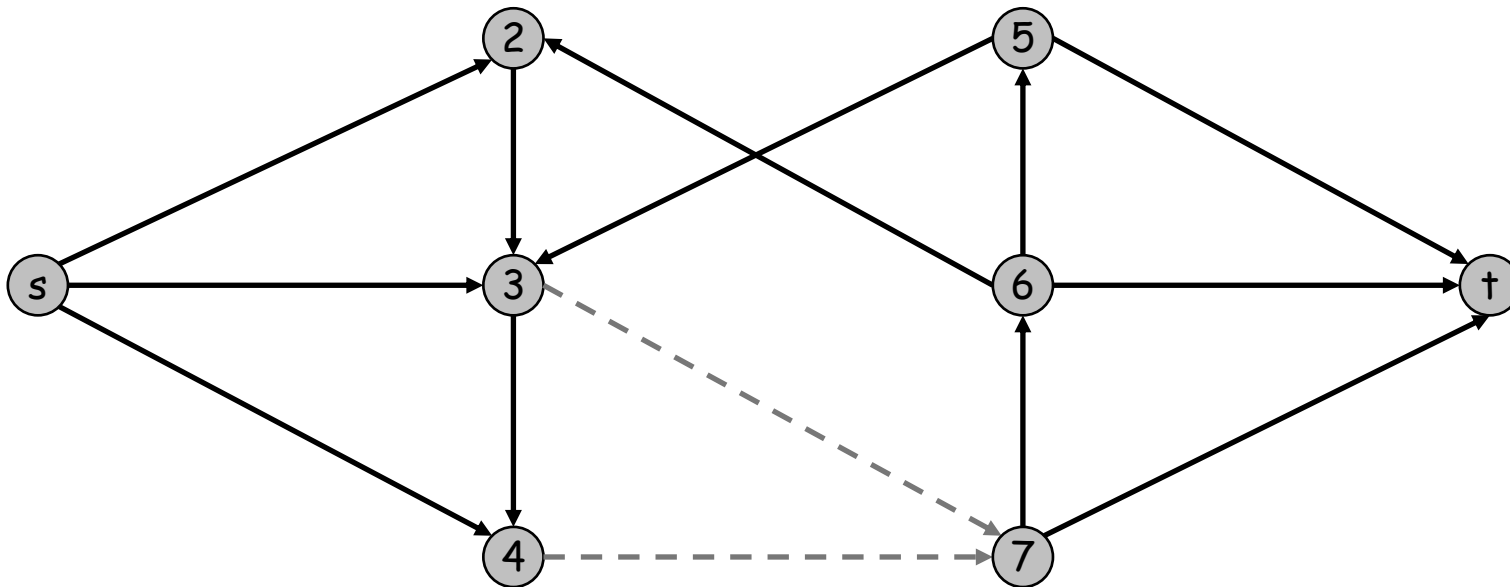

## Edge Disjoint Paths and Network Connectivity

**Theorem.** [Menger 1927] The max number of edge-disjoint  $s$ - $t$  paths is equal to the min number of edges whose removal disconnects  $t$  from  $s$ .

Pf.  $\leq$

- Suppose the removal of  $F \subseteq E$  disconnects  $t$  from  $s$ , and  $|F| = k$ .
- All  $s$ - $t$  paths use at least one edge of  $F$ . Hence, the number of edge-disjoint paths is at most  $k$ . ▀

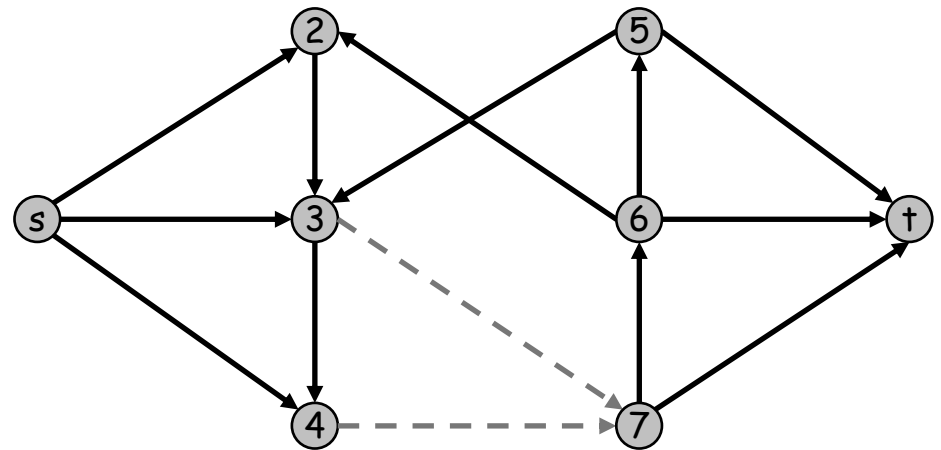
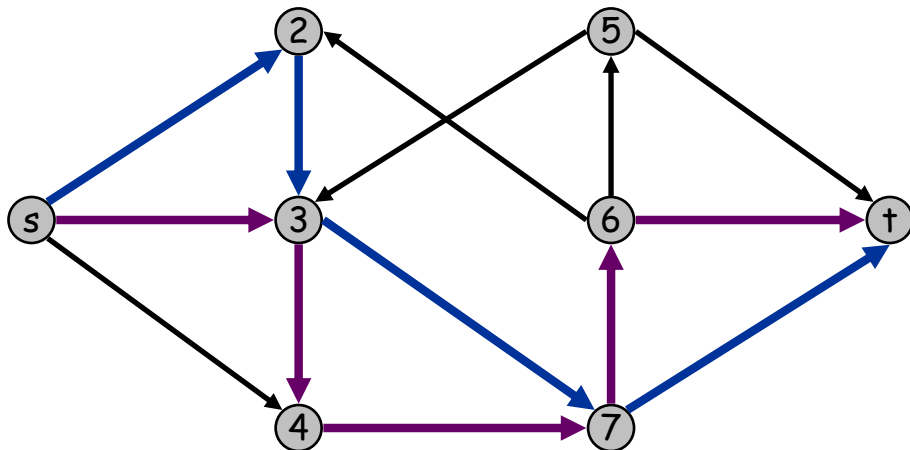

# Disjoint Paths and Network Connectivity

**Theorem.** [Menger 1927] The max number of edge-disjoint  $s$ - $t$  paths is equal to the min number of edges whose removal disconnects  $t$  from  $s$ .

Pf.  $\geq$

- Suppose max number of edge-disjoint paths is  $k$ .
- Then max flow value is  $k$ .
- Max-flow min-cut  $\Rightarrow$  cut  $(A, B)$  of capacity  $k$ .
- Let  $F$  be set of edges going from  $A$  to  $B$ .
- $|F| = k$  and disconnects  $t$  from  $s$ .

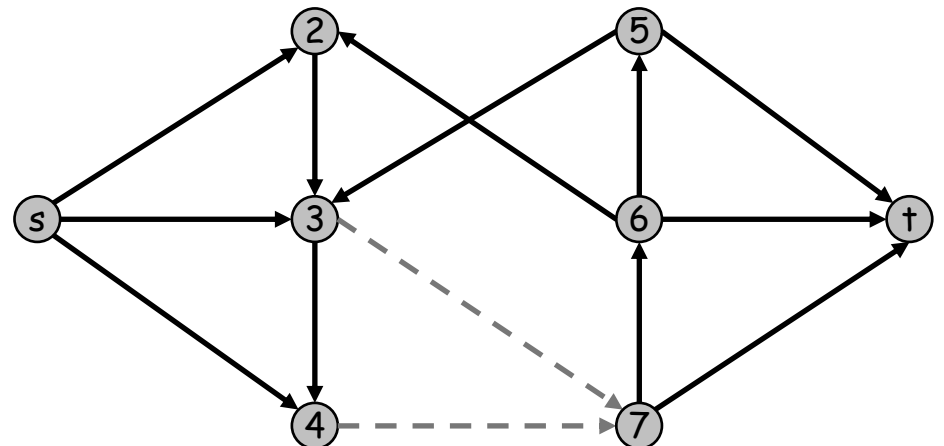
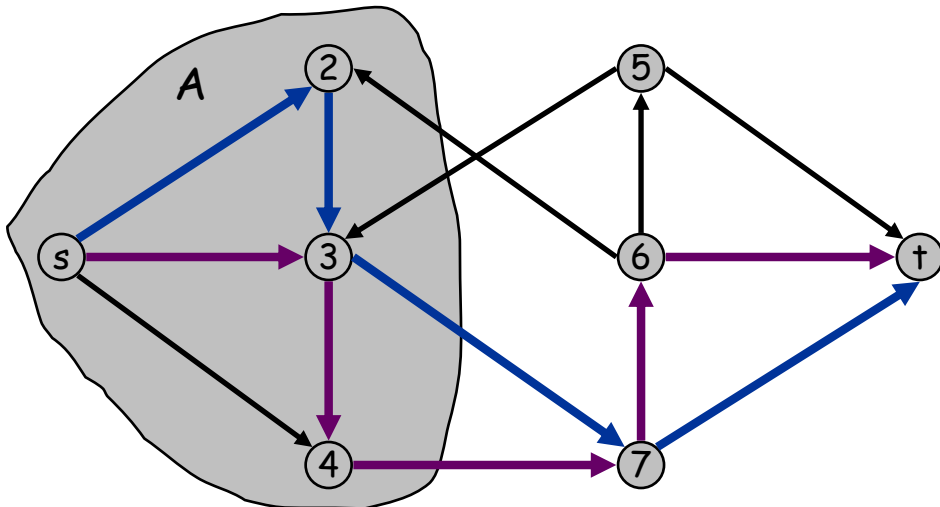

## 7.7 Extensions to Max Flow

---

# Circulation with Demands

## Circulation with demands.

- Directed graph  $G = (V, E)$ .
- Edge capacities  $c(e)$ ,  $e \in E$ .
- Node supply and demands  $d(v)$ ,  $v \in V$ .



demand if  $d(v) > 0$ ; supply if  $d(v) < 0$ ; transshipment if  $d(v) = 0$

**Def.** A **circulation** is a function that satisfies:

- For each  $e \in E$ :  $0 \leq f(e) \leq c(e)$  (capacity)
- For each  $v \in V$ :  $\sum_{e \text{ in to } v} f(e) - \sum_{e \text{ out of } v} f(e) = d(v)$  (conservation)

**Circulation problem:** given  $(V, E, c, d)$ , does there exist a circulation?

## Circulation with Demands

Necessary condition: sum of supplies = sum of demands.

$$\sum_{v: d(v) > 0} d(v) = \sum_{v: d(v) < 0} -d(v) =: D$$

Pf. Sum conservation constraints for every demand node  $v$ .

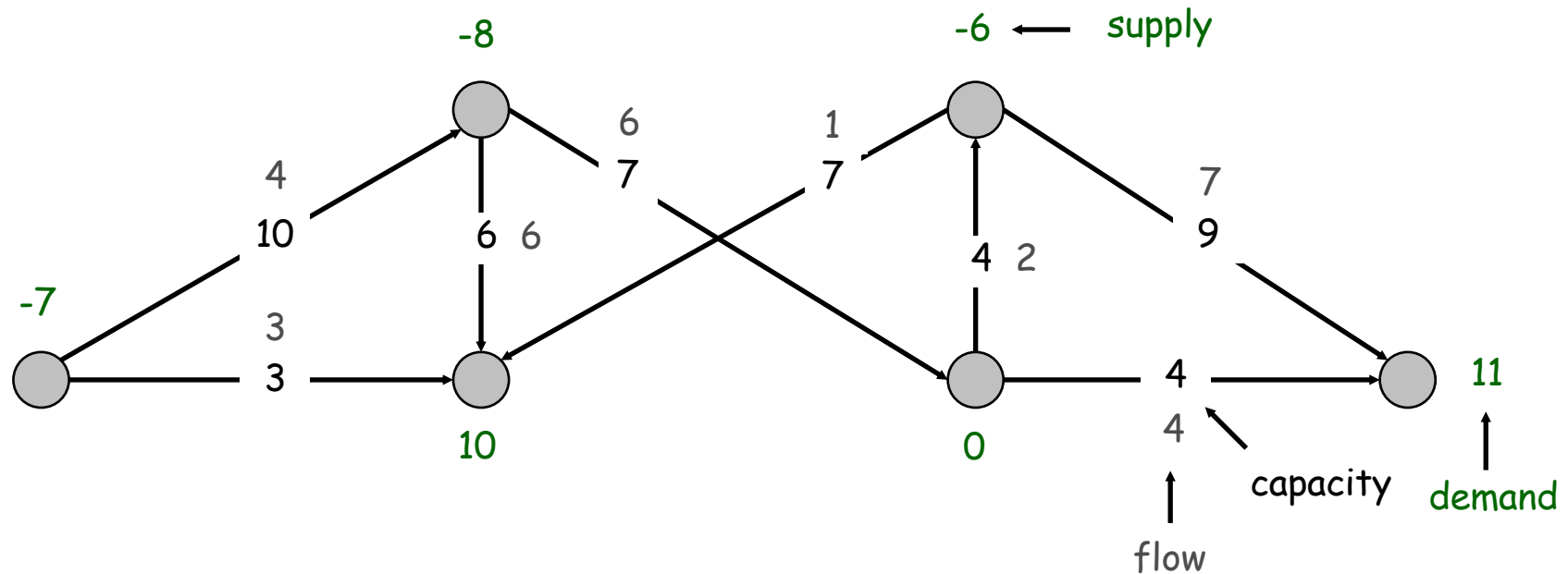

# Circulation with Demands

Max flow formulation.

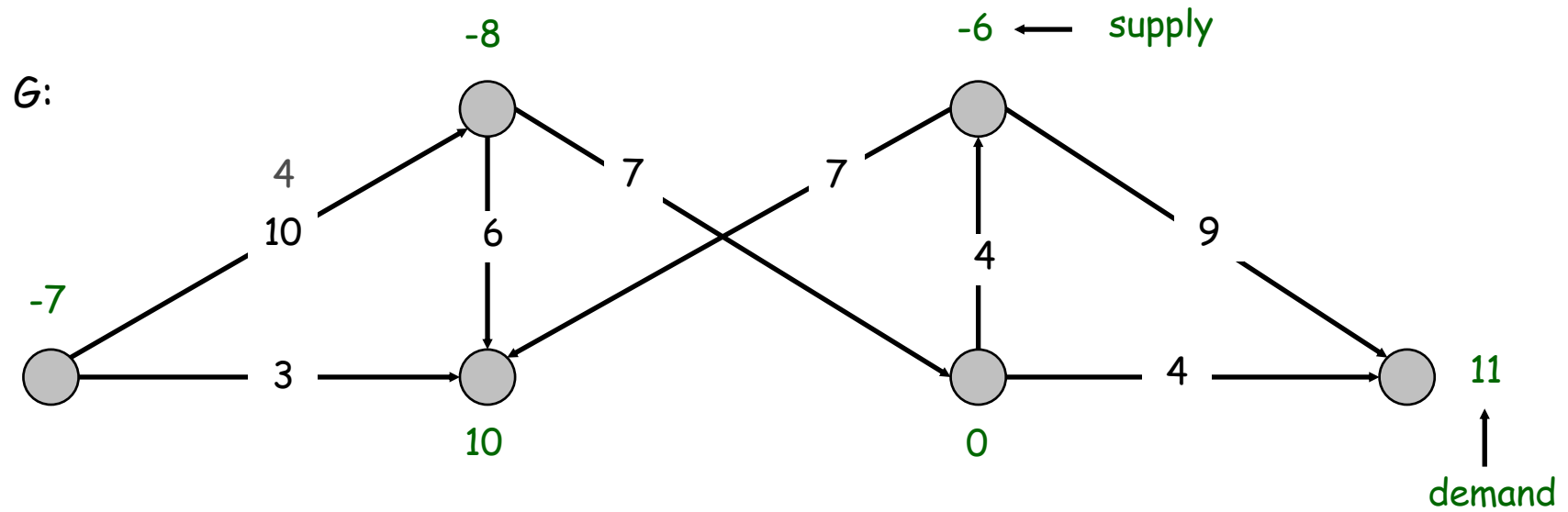

# Circulation with Demands

## Max flow formulation.

- Add new source  $s$  and sink  $t$ .
- For each  $v$  with  $d(v) < 0$ , add edge  $(s, v)$  with capacity  $-d(v)$ .
- For each  $v$  with  $d(v) > 0$ , add edge  $(v, t)$  with capacity  $d(v)$ .
- Claim:  $G$  has circulation iff  $G'$  has max flow of value  $D$ .

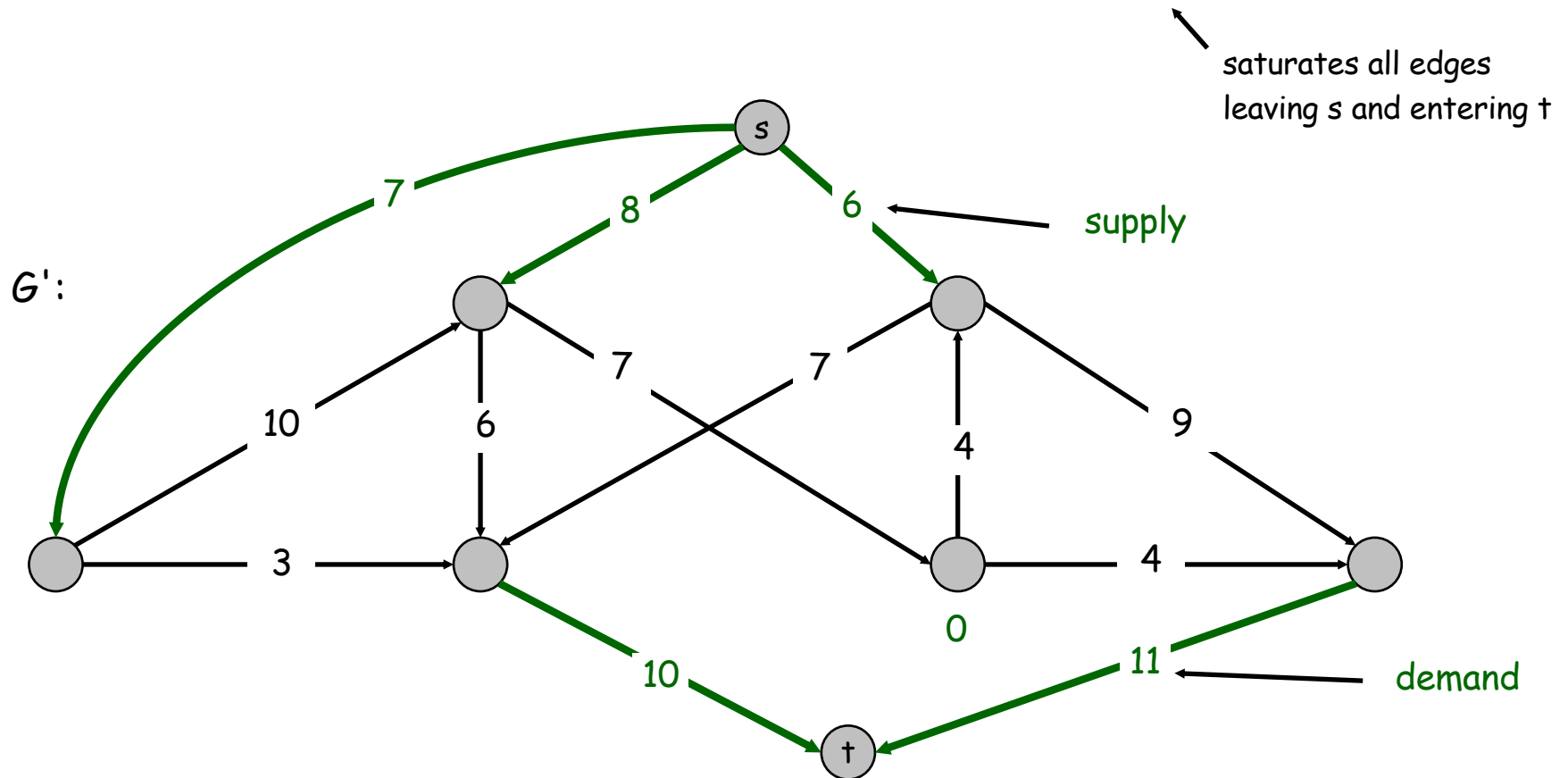



## Circulation with Demands

**Integrality theorem.** If all capacities and demands are integers, and there exists a circulation, then there exists one that is integer-valued.

**Pf.** Follows from max flow formulation and integrality theorem for max flow.

**Characterization.** Given  $(V, E, c, d)$ , there does **not** exist a circulation iff there exists a node partition  $(A, B)$  such that  $\sum_{v \in B} d_v > \text{cap}(A, B)$

**Pf idea.** Look at min cut in  $G'$ .

↑  
demand by nodes in B exceeds supply of nodes in B plus max capacity of edges going from A to B

## 7.10 Image Segmentation

---

# Image Segmentation

Image segmentation.

- Central problem in image processing.
- Divide image into coherent regions.

**Ex:** Three people standing in front of complex background scene.  
Identify each person as a coherent object.

# Image Segmentation

## Foreground / background segmentation.

- Label each pixel in picture as belonging to foreground or background.
- $V$  = set of pixels,  $E$  = pairs of neighboring pixels.
- $a_i \geq 0$  is likelihood pixel  $i$  in foreground.
- $b_i \geq 0$  is likelihood pixel  $i$  in background.
- $p_{ij} \geq 0$  is separation penalty for labeling one of  $i$  and  $j$  as foreground, and the other as background.

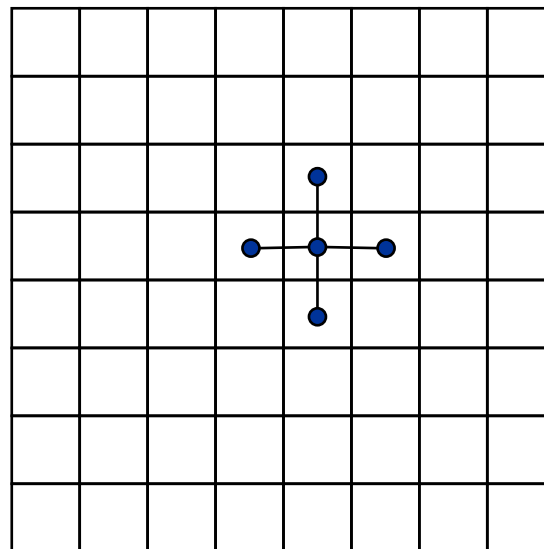

## Goals.

- Accuracy: if  $a_i > b_i$  in isolation, prefer to label  $i$  in foreground.
- Smoothness: if many neighbors of  $i$  are labeled foreground, we should be inclined to label  $i$  as foreground.

- Find partition  $(A, B)$  that maximizes:
 
$$\sum_{\substack{i \in A \\ \nearrow \\ \text{foreground}}} a_i + \sum_{\substack{j \in B \\ \searrow \\ \text{background}}} b_j - \sum_{\substack{(i,j) \in E \\ |A \cap \{i,j\}| = 1}} p_{ij}$$

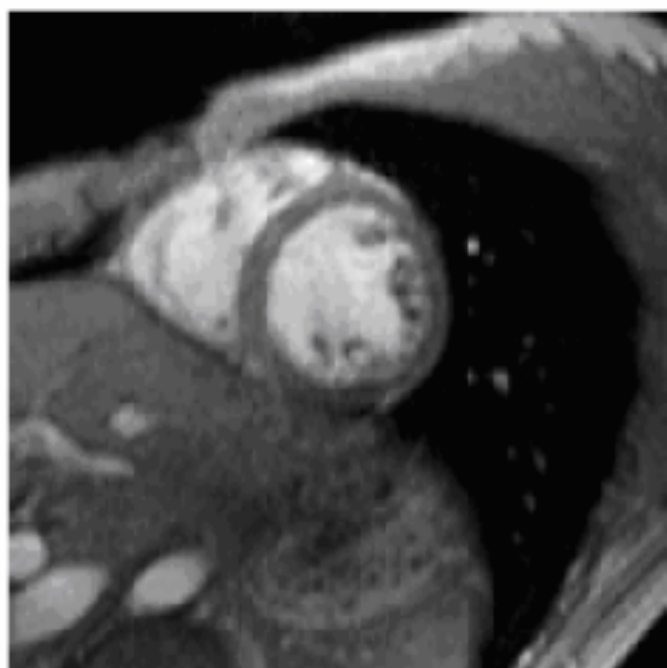

Original image

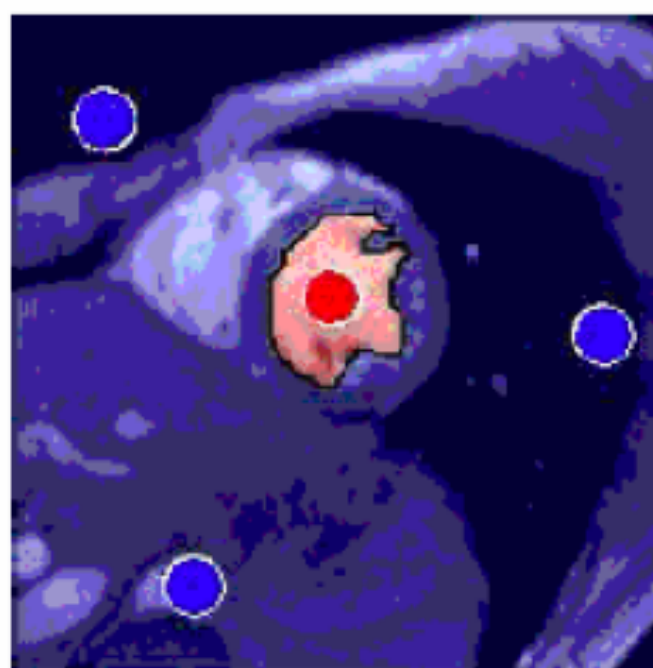

A minimum cut

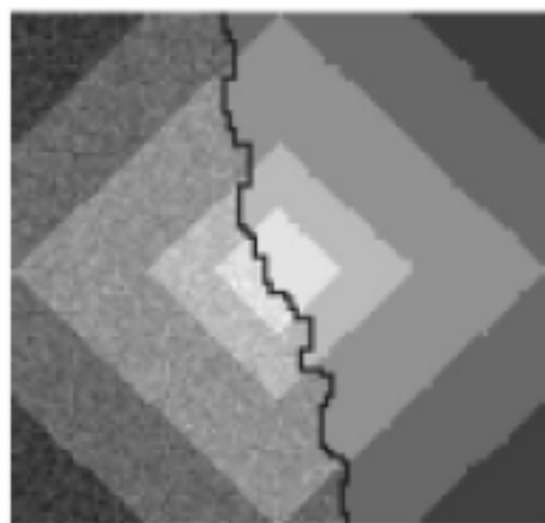

(a) *Diamond* restoration



(b) Original *Bell Quad*



(c) "Restored" *Bell Quad*

J

# Interactive Foreground Segmentation

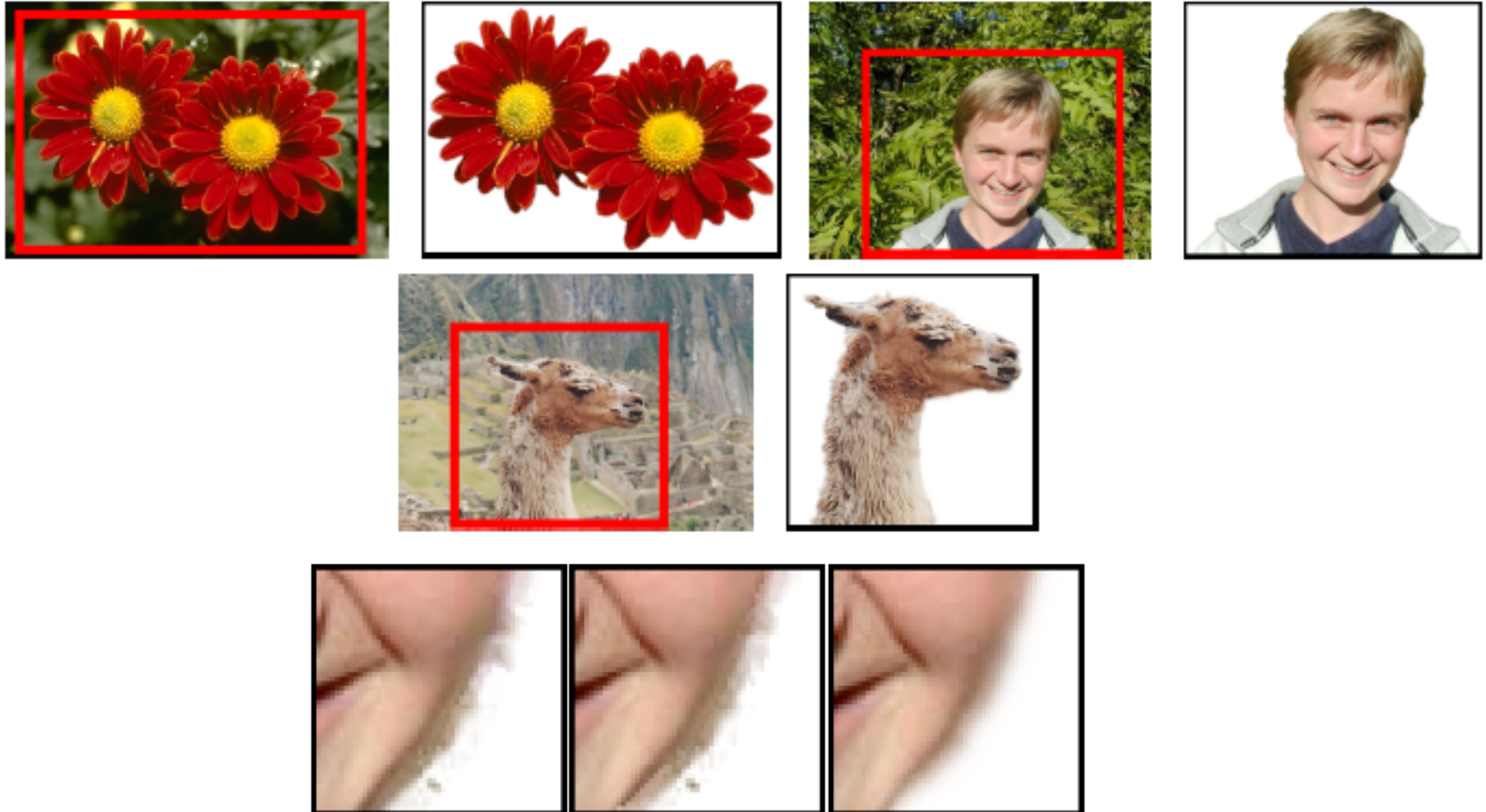

Interaction Foreground Segmentation: Grab Cuts  
Rother, Kolmogorov, Blake, SIGGRAPH 2005

# Image Segmentation

Formulate as min cut problem.

- Maximization.
- No source or sink.
- Undirected graph.

Turn into minimization problem.

- Maximizing 
$$\sum_{i \in A} a_i + \sum_{j \in B} b_j - \sum_{\substack{(i,j) \in E \\ |A \cap \{i,j\}| = 1}} p_{ij}$$

is equivalent to minimizing 
$$\underbrace{\left( \sum_{i \in V} a_i + \sum_{j \in V} b_j \right)}_{\text{a constant}} - \sum_{i \in A} a_i - \sum_{j \in B} b_j + \sum_{\substack{(i,j) \in E \\ |A \cap \{i,j\}| = 1}} p_{ij}$$

- or alternatively 
$$\sum_{j \in B} a_j + \sum_{i \in A} b_i + \sum_{\substack{(i,j) \in E \\ |A \cap \{i,j\}| = 1}} p_{ij}$$

# Image Segmentation

Formulate as min cut problem.

- $G' = (V', E')$ .
- Add source to correspond to foreground; add sink to correspond to background
- Use two anti-parallel edges instead of undirected edge.

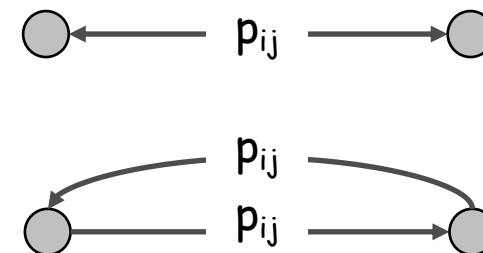

$G'$

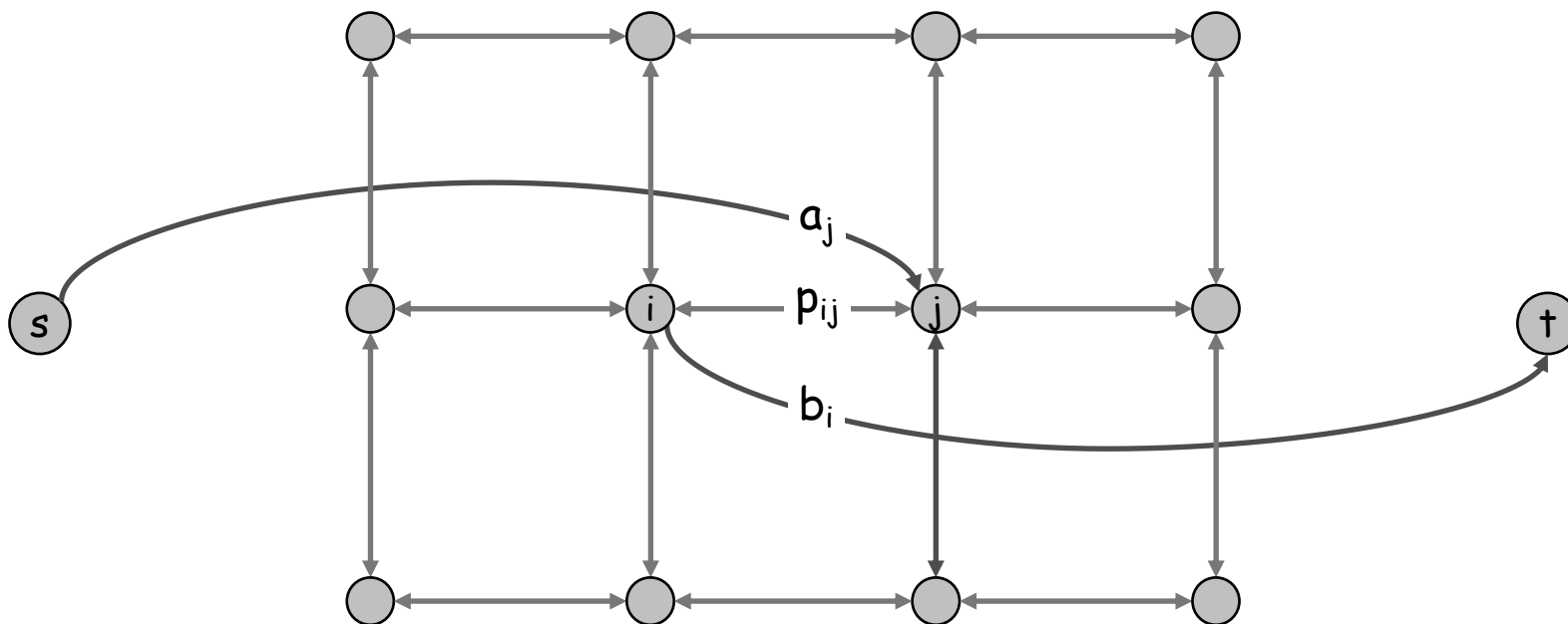



# Image Segmentation

Consider min cut  $(A, B)$  in  $G'$ .

- $A$  = foreground.

$$cap(A, B) = \sum_{j \in B} a_j + \sum_{i \in A} b_i + \sum_{\substack{(i,j) \in E \\ i \in A, j \in B}} p_{ij} \quad \leftarrow \begin{array}{l} \text{if } i \text{ and } j \text{ on different sides,} \\ p_{ij} \text{ counted exactly once} \end{array}$$

- Precisely the quantity we want to minimize.

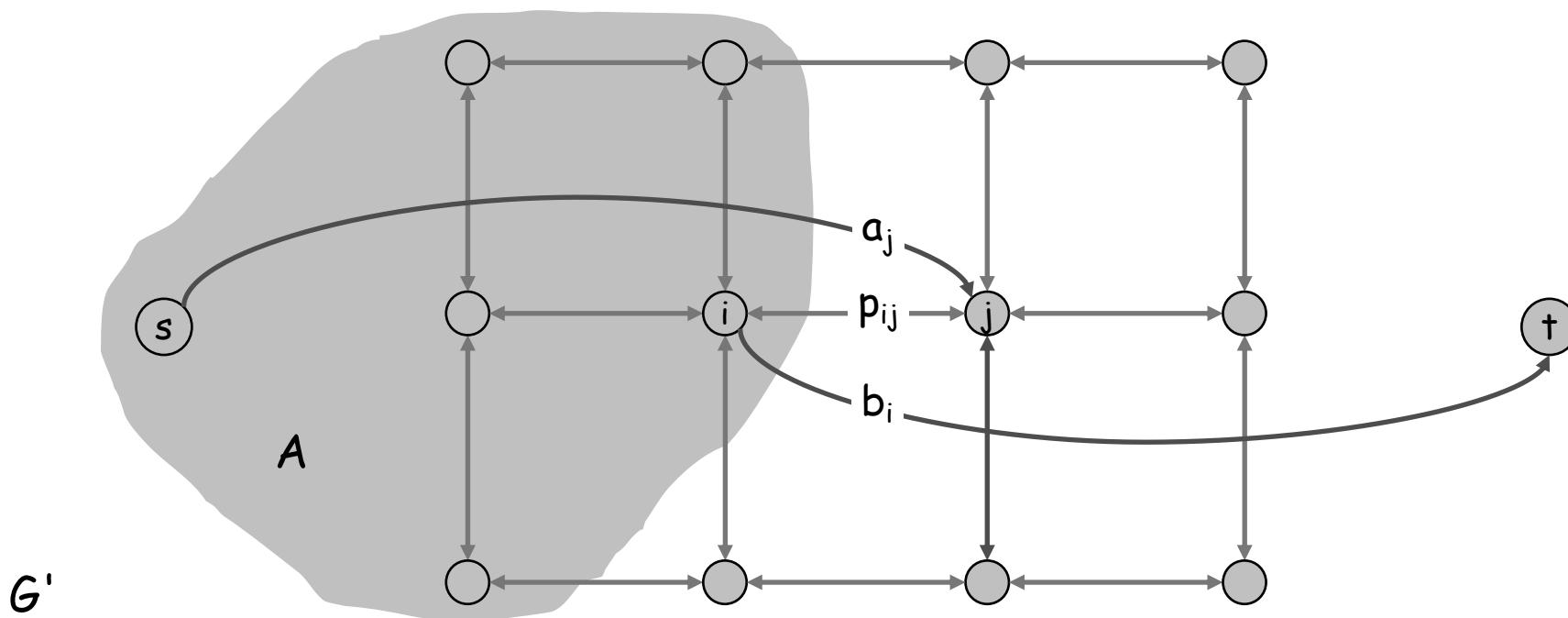

# Graph Cut

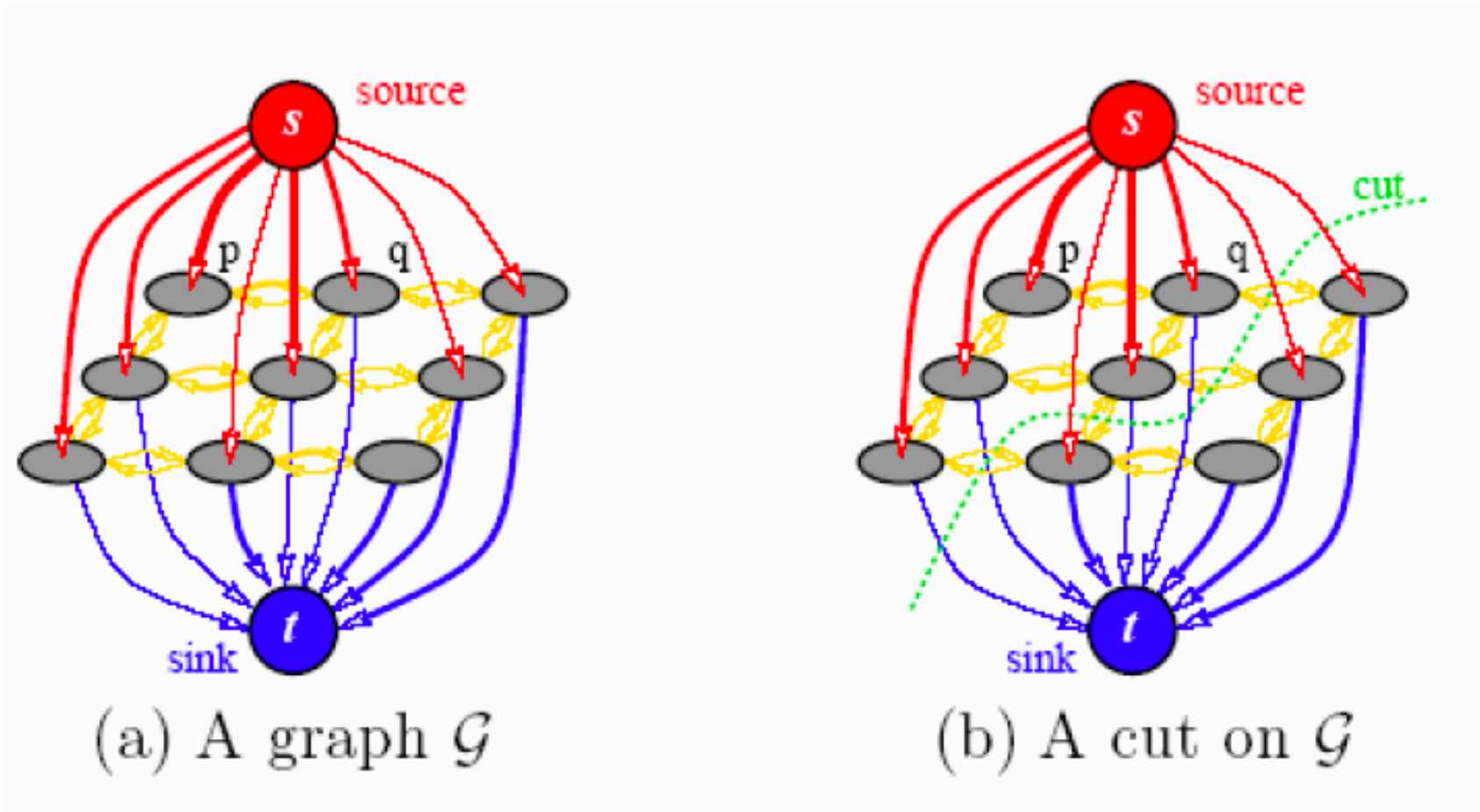

Formulated as maximum cost flow - Network flow problem from Graph Theory  
Kolmogorov, Boykov (et al)

## Ex.: Foreground/Background Segmentation

- Two categories: regions of interest/background
- Segmentation of CT scans into organs (lungs, heart etc)
- Binary segmentation (regions and background)

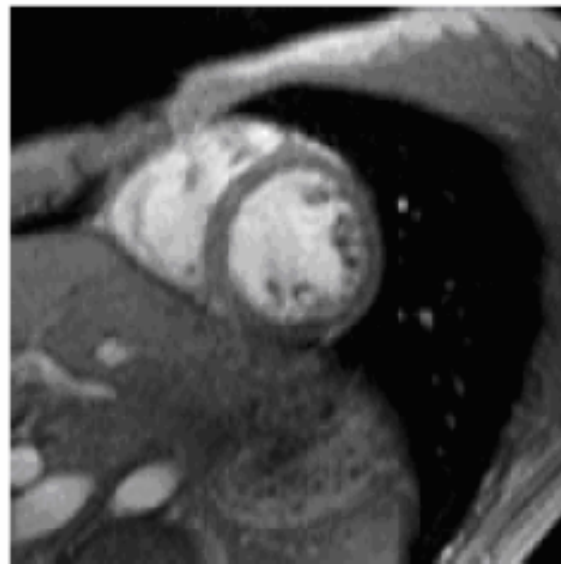

Original image

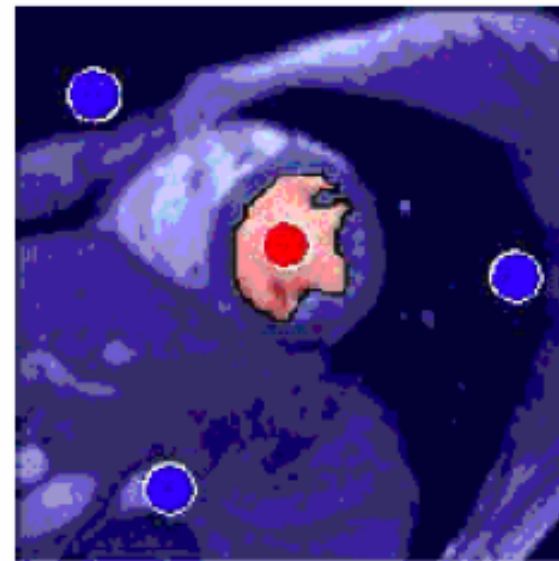

A minimum cut

# Ex: Interactive Foreground Segmentation

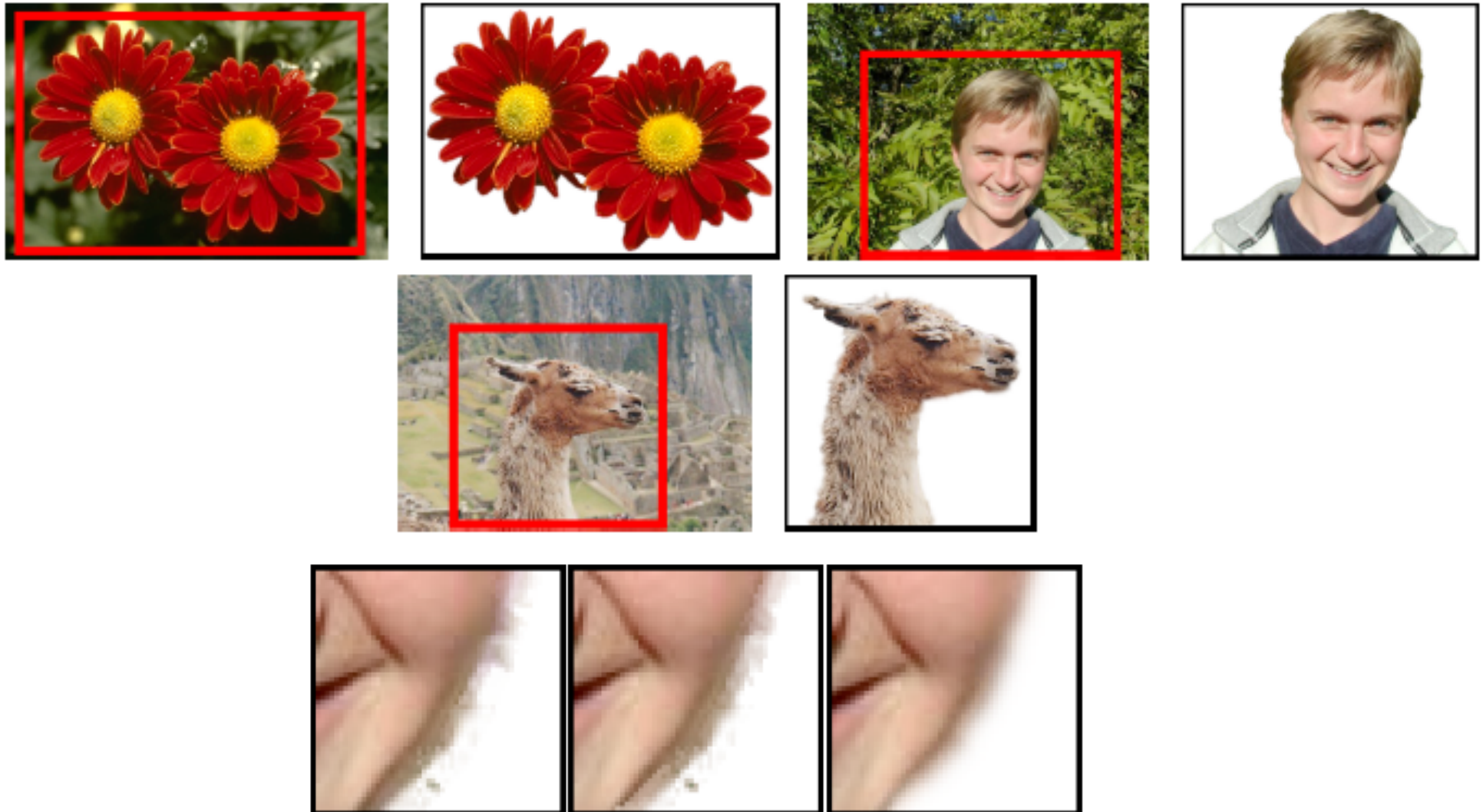

Interaction Foreground Segmentation: Grab Cuts  
Rother, Kolmogorov, Blake, SIGGRAPH 2005

## 7.11 Project Selection

---

# Project Selection

## Projects with prerequisites.

can be positive or negative



- Set  $P$  of possible projects. Project  $v$  has associated revenue  $p_v$ .
  - some projects generate money: create interactive e-commerce interface, redesign web page
  - others cost money: upgrade computers, get site license
- Set of prerequisites  $E$ . If  $(v, w) \in E$ , can't do project  $v$  and unless also do project  $w$ .
- A subset of projects  $A \subseteq P$  is **feasible** if the prerequisite of every project in  $A$  also belongs to  $A$ .

**Project selection.** Choose a feasible subset of projects to maximize revenue. General framework for modeling similar decisions.

# Project Selection: Prerequisite Graph

## Prerequisite graph.

- Include an edge from  $v$  to  $w$  if can't do  $v$  without also doing  $w$ .
- $\{v, w, x\}$  is feasible subset of projects.
- $\{v, x\}$  is infeasible subset of projects.
- Select a set of projects  $A$  such that every project in  $A$  has also prerequisite in  $A$

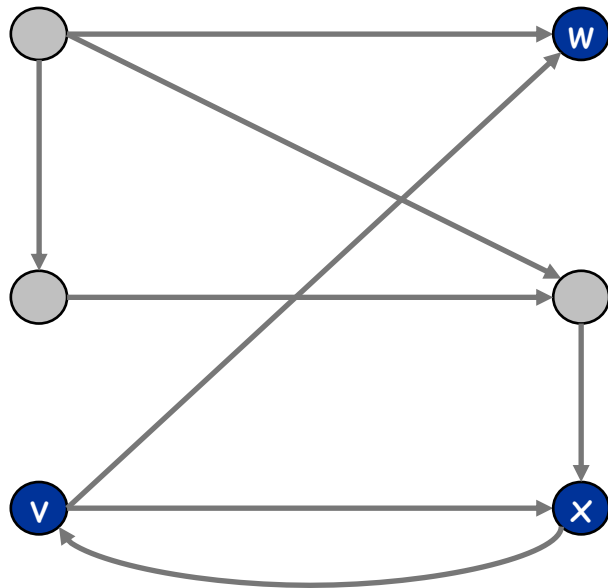

feasible

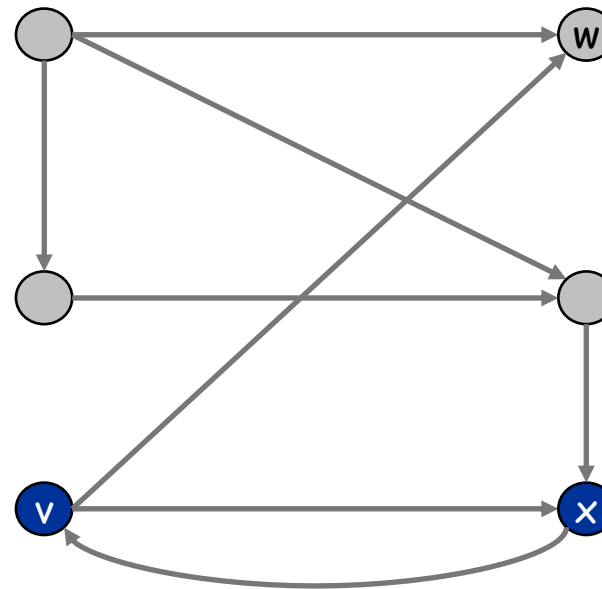

infeasible

# Project Selection: Min Cut Formulation

## Min cut formulation.

- Assign capacity  $\infty$  to all prerequisite edge.
- Add edge  $(s, v)$  with capacity  $p_v$  if  $p_v > 0$ .
- Add edge  $(v, t)$  with capacity  $-p_v$  if  $p_v < 0$ .
- For notational convenience, define  $p_s = p_t = 0$ .

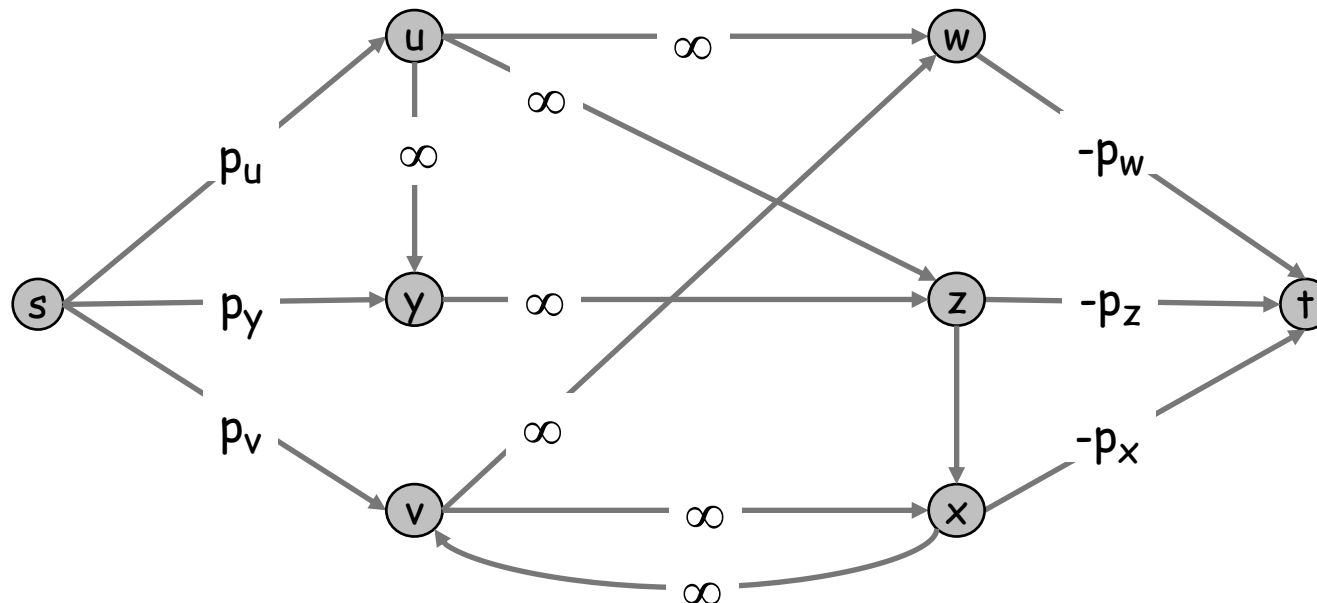



## Project Selection: Min Cut Formulation

**Claim.**  $(A, B)$  is min cut iff  $A - \{s\}$  is optimal set of projects.

- Infinite capacity edges ensure  $A - \{s\}$  is feasible.

- Max revenue because:

$$\text{cap}(A, B) = \sum_{v \in B: p_v > 0} p_v + \sum_{v \in A: p_v < 0} (-p_v)$$

- Max revenue, capacity of the cut

$$= \underbrace{\sum_{v: p_v > 0} p_v}_{\text{constant}} - \sum_{v \in A} p_v$$

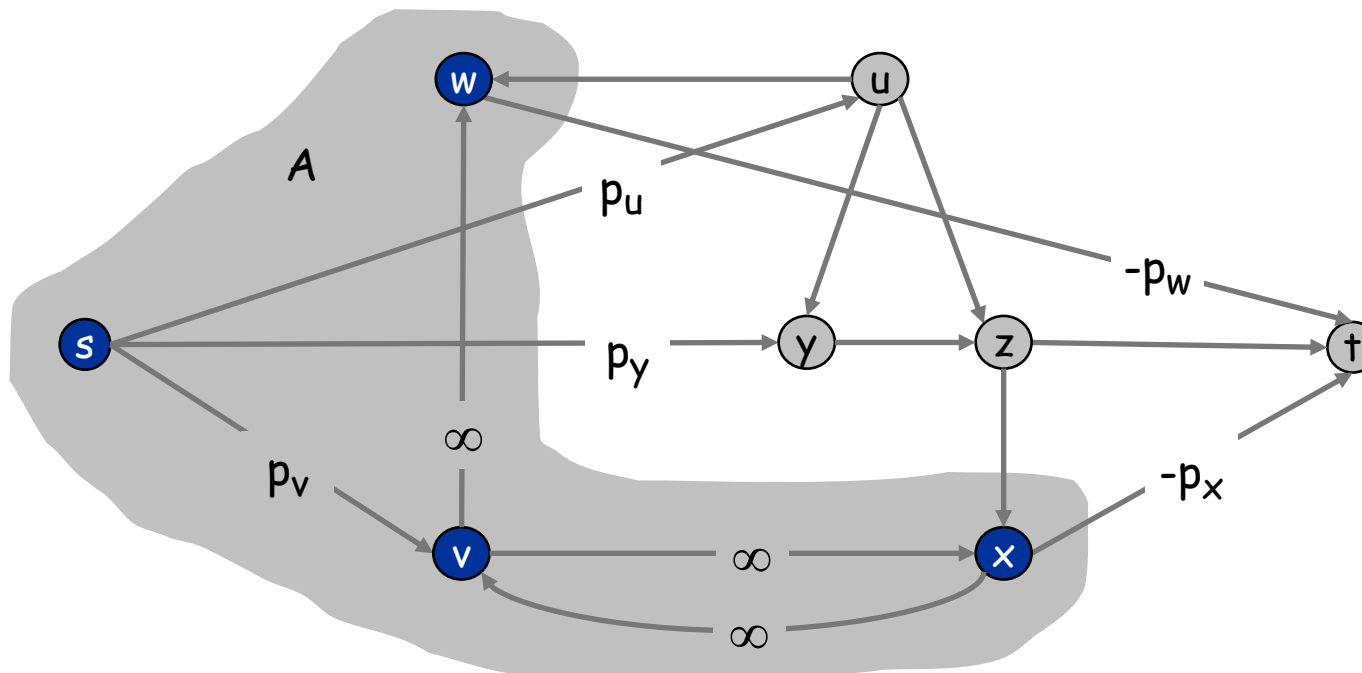

## 7.12 Baseball Elimination

---

"See that thing in the paper last week about Einstein? . . . Some reporter asked him to figure out the mathematics of the pennant race. You know, one team wins so many of their remaining games, the other teams win this number or that number. What are the myriad possibilities? Who's got the edge?"

"The hell does he know?"

"Apparently not much. He picked the Dodgers to eliminate the Giants last Friday."

- *Don DeLillo, Underworld*

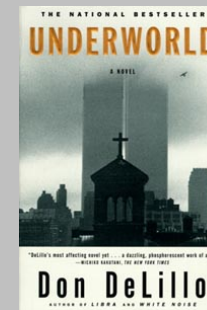

## Baseball Elimination

Team $i$	Wins $w_i$	Losses $l_i$	To play $r_i$	Against = $r_{ij}$			
				Atl	Phi	NY	Mon
Atlanta	83	71	8	-	1	6	1
Philly	80	79	3	1	-	0	2
New York	78	78	6	6	0	-	0
<b>Montreal</b>	77	82	3	1	2	0	-

Which teams have a chance of finishing the season with most wins?

- Montreal eliminated since it can finish with at most 80 wins, but Atlanta already has 83.
- $w_i + r_i < w_j \Rightarrow$  team  $i$  eliminated.
- Only reason sports writers appear to be aware of.
- Sufficient, but not necessary!

## Baseball Elimination

Team $i$	Wins $w_i$	Losses $l_i$	To play $r_i$	Against = $r_{ij}$			
				Atl	Phi	NY	Mon
Atlanta	83	71	8	-	1	6	1
Philly	80	79	3	1	-	0	2
New York	78	78	6	6	0	-	0
Montreal	77	82	3	1	2	0	-

Which teams have a chance of finishing the season with most wins?

- Philly can win 83, but still eliminated . . .
- If Atlanta loses a game, then some other team wins one.

**Remark.** Answer depends not just on **how many** games already won and left to play, but also on **whom** they're against.

# Baseball Elimination

Baseball elimination problem.

- Set of teams  $S$ .
- Distinguished team  $s \in S$ .
- Team  $x$  has won  $w_x$  games already.
- Teams  $x$  and  $y$  play each other  $r_{xy}$  additional times.
- Is there any outcome of the remaining games in which team  $s$  finishes with the most (or tied for the most) wins?

# Baseball Elimination: Max Flow Formulation

Can team 3 finish with most wins?

- Assume team 3 wins all remaining games  $\Rightarrow w_3 + r_3$  wins.
- Divvy remaining games so that all teams have  $\leq w_3 + r_3$  wins.

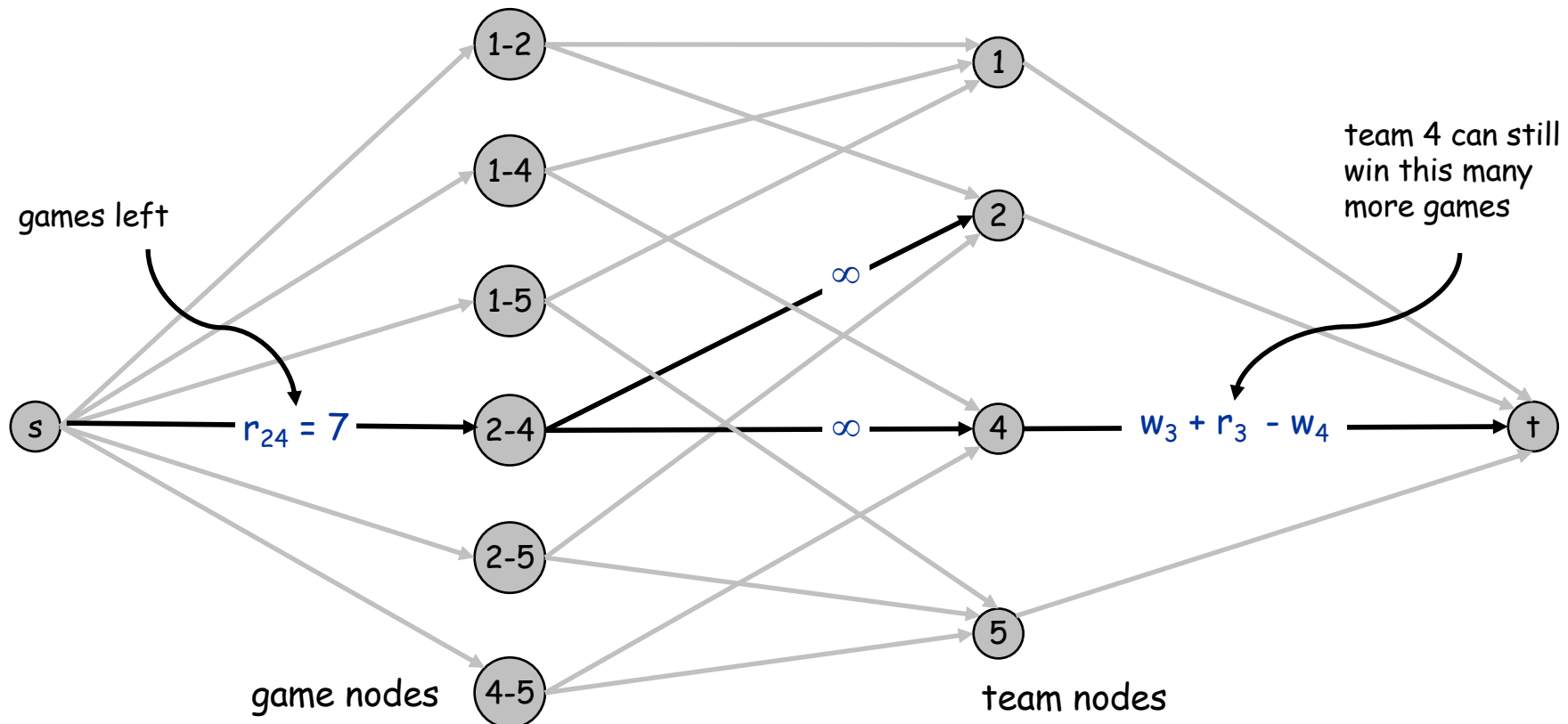

# Baseball Elimination: Max Flow Formulation

**Theorem.** Team 3 is not eliminated iff max flow saturates all edges leaving source.

- Integrality theorem  $\Rightarrow$  each remaining game between  $x$  and  $y$  added to number of wins for team  $x$  or team  $y$ .
- Capacity on  $(x, t)$  edges ensure no team wins too many games.

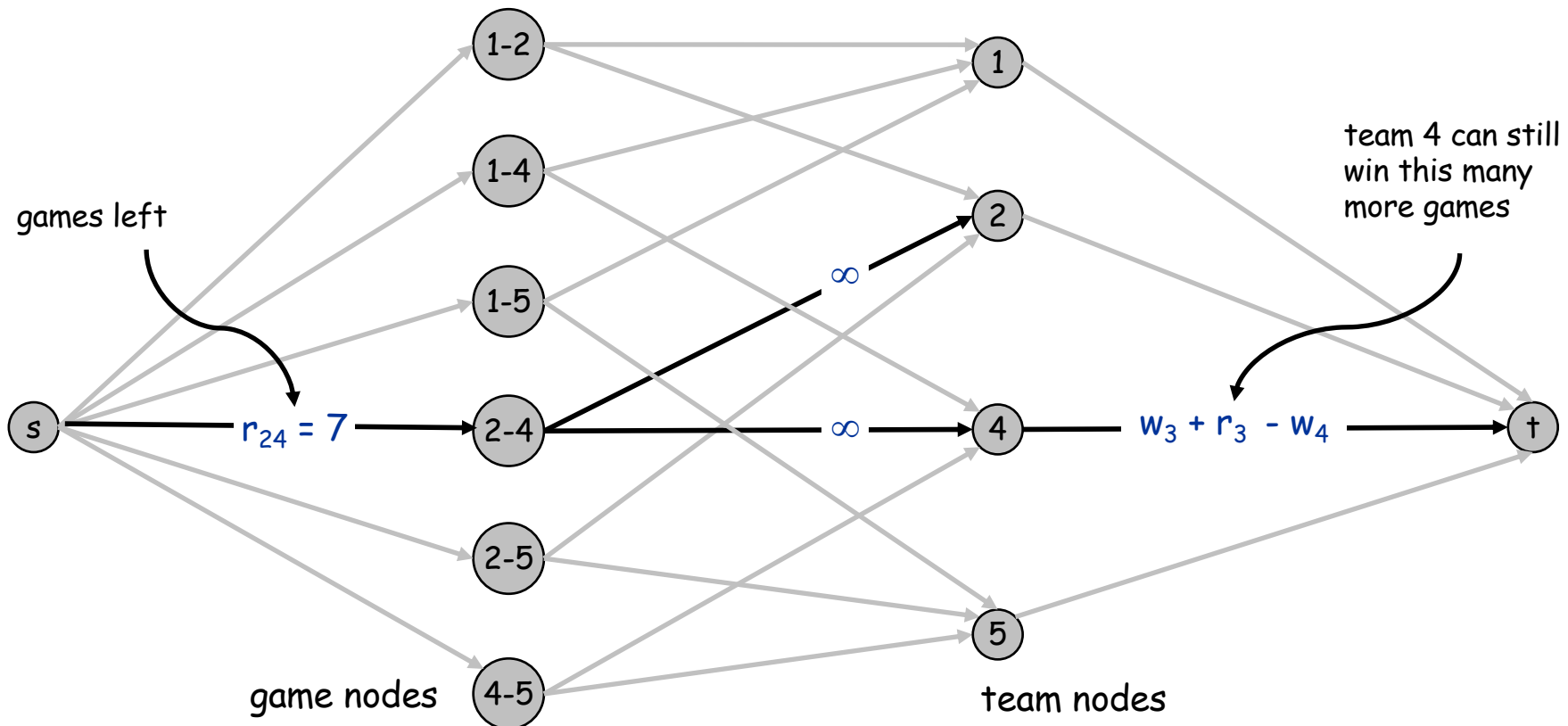

## Baseball Elimination: Explanation for Sports Writers

Team $i$	Wins $w_i$	Losses $l_i$	To play $r_i$	Against = $r_{ij}$				
				NY	Bal	Bos	Tor	Det
NY	75	59	28	-	3	8	7	3
Baltimore	71	63	28	3	-	2	7	4
Boston	69	66	27	8	2	-	0	0
Toronto	63	72	27	7	7	0	-	-
<b>Detroit</b>	49	86	27	3	4	0	0	-

AL East: August 30, 1996

Which teams have a chance of finishing the season with most wins?

- Detroit could finish season with  $49 + 27 = 76$  wins.



## Baseball Elimination: Explanation for Sports Writers

Team $i$	Wins $w_i$	Losses $l_i$	To play $r_i$	Against = $r_{ij}$				
				NY	Bal	Bos	Tor	Det
NY	75	59	28	-	3	8	7	3
Baltimore	71	63	28	3	-	2	7	4
Boston	69	66	27	8	2	-	0	0
Toronto	63	72	27	7	7	0	-	-
<b>Detroit</b>	49	86	27	3	4	0	0	-

AL East: August 30, 1996

Which teams have a chance of finishing the season with most wins?

- Detroit could finish season with  $49 + 27 = 76$  wins.

*Certificate of elimination.*  $R = \{\text{NY, Bal, Bos, Tor}\}$

- Have already won  $w(R) = 278$  games.
- Must win at least  $r(R) = 27$  more.
- Average team in  $R$  wins at least  $305/4 > 76$  games.

# Baseball Elimination: Explanation for Sports Writers

Certificate of elimination.

$$T \subseteq S, \quad w(T) := \overbrace{\sum_{i \in T} w_i}^{\# \text{ wins}}, \quad g(T) := \overbrace{\sum_{\{x,y\} \subseteq T} g_{xy}}^{\# \text{ remaining games}},$$

If  $\overbrace{\frac{w(T) + g(T)}{|T|}}^{\text{LB on avg \# games won}} > w_z + g_z$  then  $z$  is **eliminated** (by subset  $T$ ).

**Theorem.** [Hoffman-Rivlin 1967] Team  $z$  is eliminated iff there exists a subset  $T^*$  that eliminates  $z$ .

**Proof idea.** Let  $T^*$  = team nodes on source side of min cut.

# Baseball Elimination: Explanation for Sports Writers

Pf of theorem.

- Use max flow formulation, and consider min cut  $(A, B)$ .
- Define  $T^*$  = team nodes on source side of min cut.
- Observe  $x-y \in A$  iff both  $x \in T^*$  and  $y \in T^*$ .
  - infinite capacity edges ensure if  $x-y \in A$  then  $x \in A$  and  $y \in A$
  - if  $x \in A$  and  $y \in A$  but  $x-y \in T$ , then adding  $x-y$  to  $A$  decreases capacity of cut

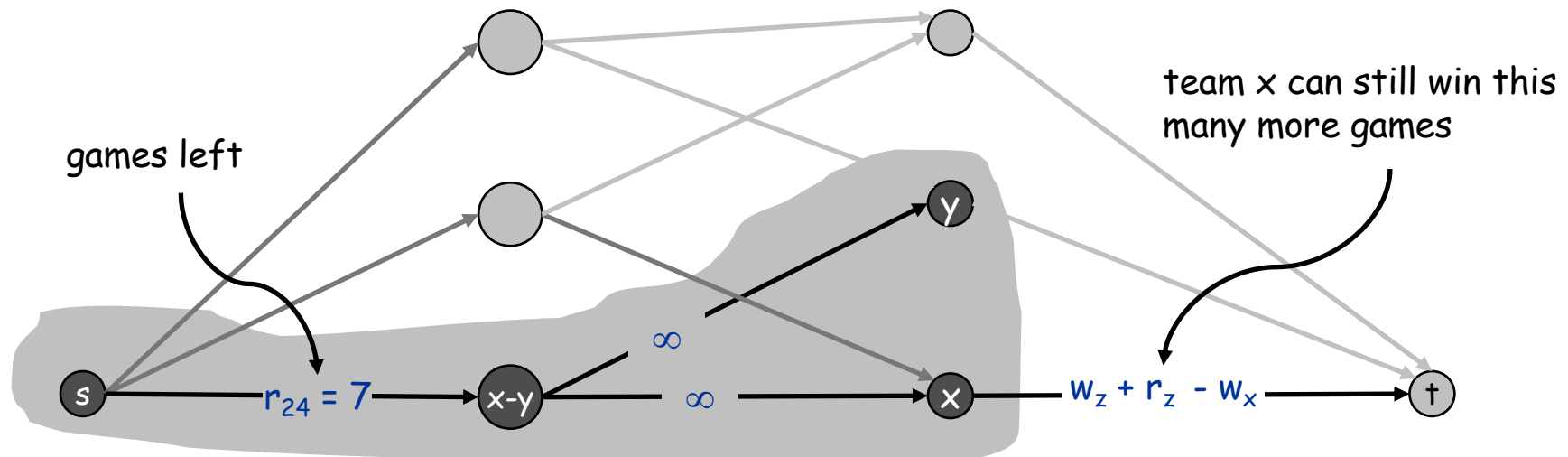

## Baseball Elimination: Explanation for Sports Writers

Pf of theorem.

- Use max flow formulation, and consider min cut  $(A, B)$ .
- Define  $T^*$  = team nodes on source side of min cut.
- Observe  $x-y \in A$  iff both  $x \in T^*$  and  $y \in T^*$ .
- $g(S - \{z\}) > \text{cap}(A, B)$

$$\begin{aligned}
 &= \overbrace{g(S - \{z\}) - g(T^*)}^{\text{capacity of game edges leaving } s} + \overbrace{\sum_{x \in T^*} (w_z + g_z - w_x)}^{\text{capacity of team edges leaving } s} \\
 &= g(S - \{z\}) - g(T^*) - w(T^*) + |T^*|(w_z + g_z)
 \end{aligned}$$

- Rearranging terms:  $w_z + g_z < \frac{w(T^*) + g(T^*)}{|T^*|}$  .