



Chapter 1: Introduction

- What is an Operating System?
- Mainframe Systems
- Desktop Systems
- Multiprocessor Systems
- Distributed Systems
- Clustered System
- Real -Time Systems
- Handheld Systems
- Feature Migration
- Computing Environments



What is an Operating System?

- A program that acts as an intermediary between a user of a computer and the computer hardware
- Operating system goals:
 - Execute user programs and make solving user problems easier.
 - Make the computer system convenient to use
- Use the computer hardware in an efficient manner





What is an OS?

- Think about some of the things you do with a computer and think about how the OS supports them.



OS Functions

Action	OS Functions
Login	process creation, authentication, resource allocation
Create a text document	application launching, file management.
Running applications	Scheduling, resource (e.g., memory, disk) allocation.





Some OS Functions

- **User authentication**
- **Processor allocation (process scheduling)**
- **File Management**
- **Memory Management**
- **Device Management**
- **Network Management**
- **Providing a user interface (graphical or not) to system functions and resources**
- **Process synchronization**
- **Interprocess communication.**



What is an Operating System

- **Resource Manager**
- **Extended Machine:** provides higher level abstractions of lower level and complex objects (e.g., files, processes, devices)
 - complexity hidden from user
 - homogeneous treatment of different low level objects (e.g., one single *read* function can be used to read a block from any disk)



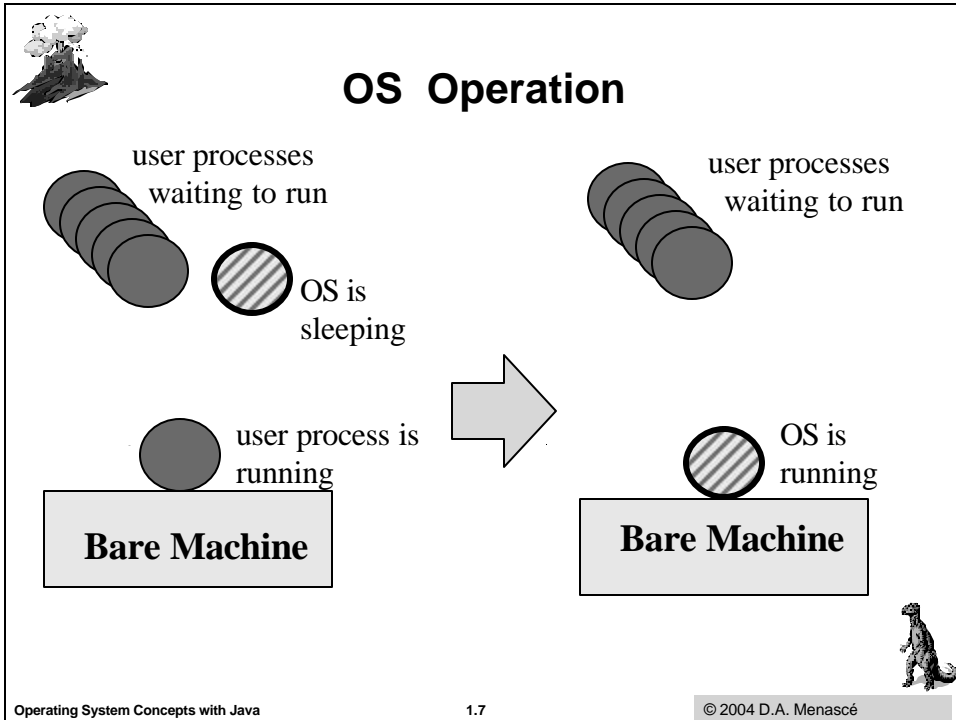

-
- Computer System Components**
1. Hardware – provides basic computing resources (CPU, memory, I/O devices)
 2. Operating system – controls and coordinates the use of the hardware among the various application programs for the various users
 3. Applications programs – define the ways in which the system resources are used to solve the computing problems of the users (compilers, database systems, video games, business programs)
 4. Users (people, machines, other computers)
- Operating System Concepts with Java 1.8 Silberschatz, Galvin and Gagne ©2003



Abstract View of System Components

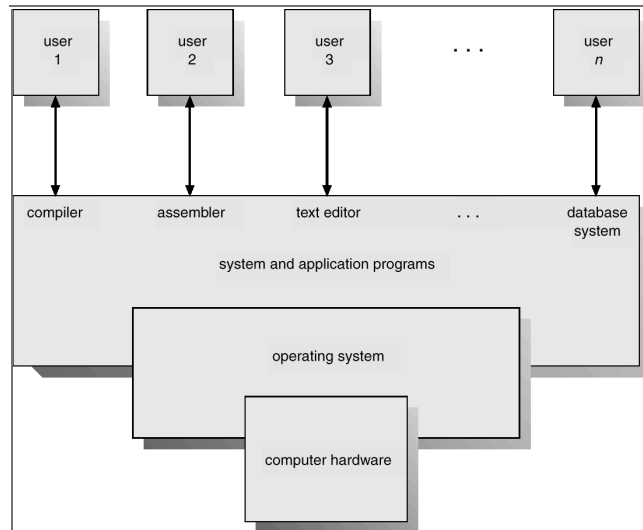

Operating System Definitions

- Resource allocator – manages and allocates resources
- Control program – controls the execution of user programs and operations of I/O devices
- Kernel – the one program running at all times (all else being application programs)





Mainframe Systems

- Reduce setup time by batching similar jobs
- Automatic job sequencing – automatically transfers control from one job to another. First rudimentary operating system
- Resident monitor
 - initial control in monitor
 - control transfers to job
 - when job completes control transfers back to monitor



IBM 7094 Mainframe – Columbia University 1965





Memory Layout for a Simple Batch System

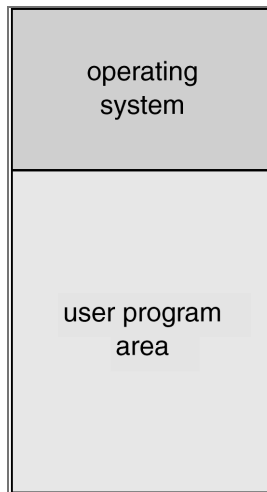

Multiprogrammed Batch Systems

Several jobs are kept in main memory at the same time, and the CPU is multiplexed among them

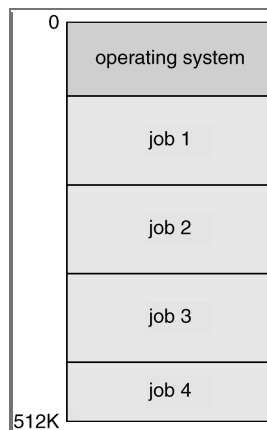



Utilization in Multiprogrammed Systems

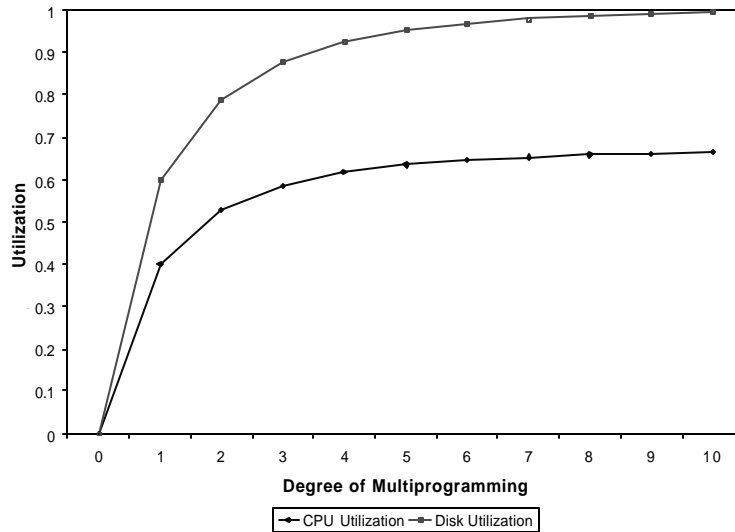

Throughput in Multiprogrammed Systems

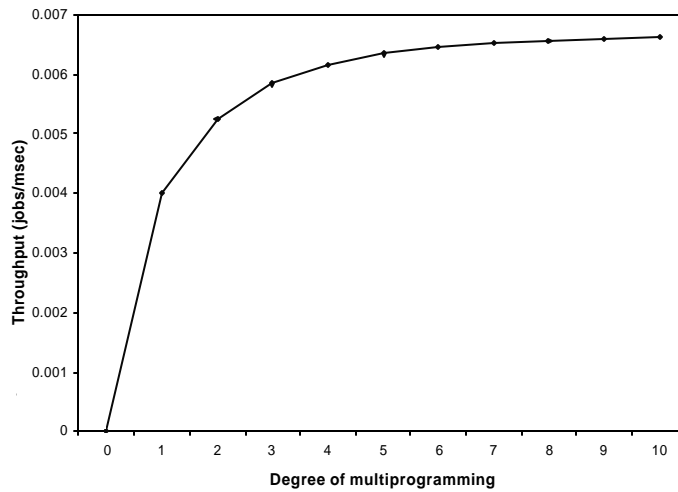



OS Features Needed for Multiprogramming

- I/O routine supplied by the system
- Memory management – the system must allocate the memory to several jobs
- CPU scheduling – the system must choose among several jobs ready to run
- Allocation of devices



Multiprogramming

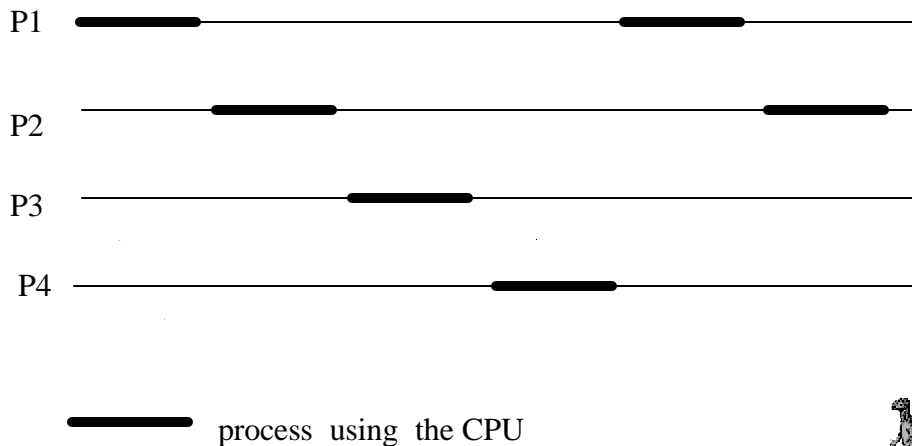



Multiprogramming

- The OS gives each process a certain timeslice (quantum) to run.
- Control is passed to another process if:
 - running process ends before timeslice expires
➔ running process leaves the system.
 - running process needs an I/O operation
➔ running process joins the I/O device queue,
 - timeslice expires
➔ running process goes back to the CPU queue.



Process States in a Multiprogrammed OS

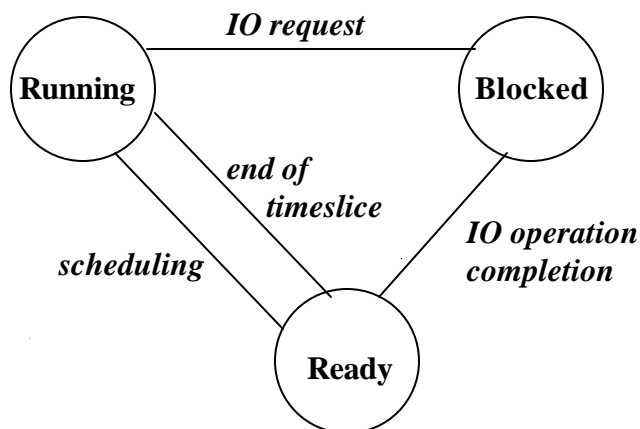



Time-Sharing Systems–Interactive Computing

- The CPU is multiplexed among several jobs that are kept in memory and on disk (the CPU is allocated to a job only if the job is in memory)
- A job is swapped in and out of memory to the disk
- On-line communication between the user and the system is provided
 - When the operating system finishes the execution of one command, it seeks the next “control statement” from the user’s keyboard
- On-line system must be available for users to access data and code



Time-sharing Queues

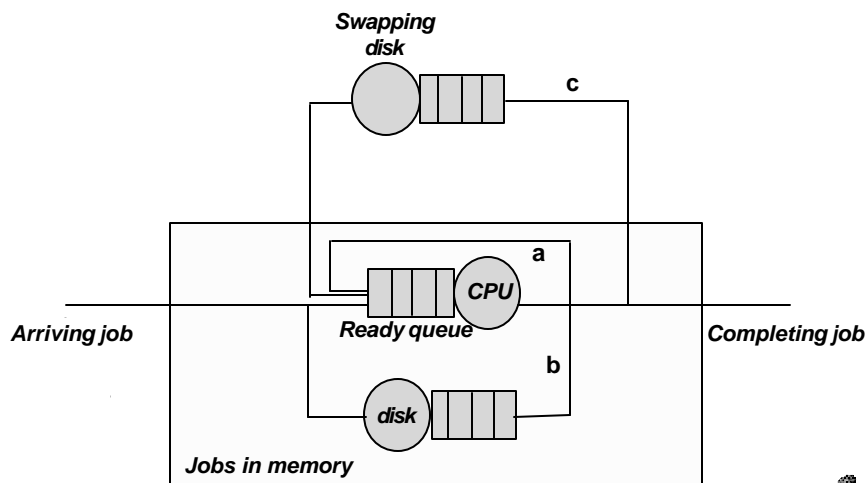



Desktop Systems

- *Personal computers* – computer system dedicated to a single user
- I/O devices – keyboards, mice, display screens, small printers
- User convenience and responsiveness
- Can adopt technology developed for larger operating system
 - Often individuals have sole use of computer and do not need advanced CPU utilization or protection features
- May run several different types of operating systems (Windows, MacOS, UNIX, Linux)



Parallel Systems

- Systems with more than one CPU in close communication
 - Also known as *multiprocessor systems*
- *Tightly coupled system* – processors share memory and a clock; communication usually takes place through the shared memory
- Advantages of parallel system:
 - Increased *throughput*
 - Economical
 - Increased reliability (in some cases)
 - ▶ graceful degradation
 - ▶ fail-soft systems





Parallel Systems

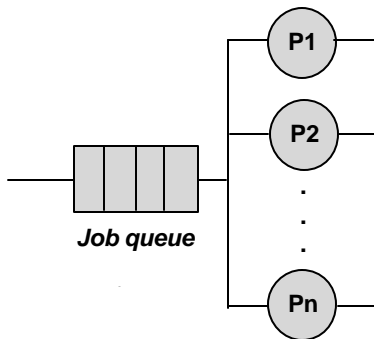

Prob. System is Up = Prob. at least one processor is up
 = $1 - \text{Prob (all processors are down)}$
 = $1 - p^n$

n	$1 - p^n$
1	0.200
2	0.360
3	0.488
4	0.590
5	0.672
6	0.738
7	0.790
8	0.832
9	0.866
10	0.893



Parallel Systems (Cont.)

- *Asymmetric multiprocessing*
 - Each processor is assigned a specific task; master processor schedules and allocated work to slave processors
 - More common in extremely large systems
- *Symmetric multiprocessing (SMP)*
 - Each processor runs and identical copy of the operating system
 - Many processes can run at once without performance deterioration
 - Most modern operating systems support SMP





Symmetric Multiprocessing Architecture

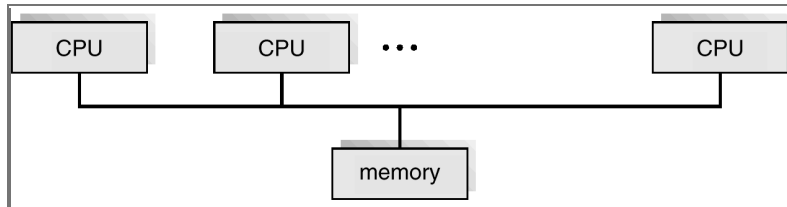

Distributed Systems

- Distribute the computation among several physical processors
- *Loosely coupled system* – each processor has its own local memory; processors communicate with one another through various communications lines, such as high-speed buses or telephone lines
- Advantages of distributed systems
 - Resources Sharing
 - Computation speed up – load sharing
 - Reliability
 - Communications





Distributed Systems (cont)

- Requires networking infrastructure
- Local area networks (*LAN*) or Wide area networks (*WAN*)
- May be either *client-server* or *peer-to-peer* systems



General Structure of Client-Server

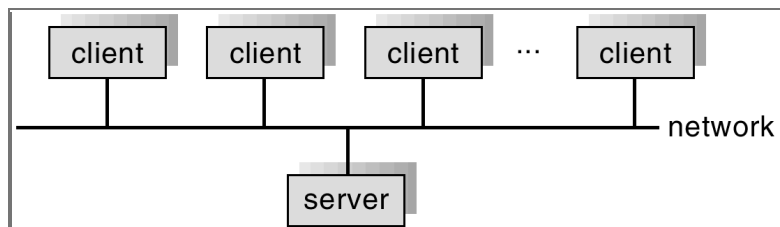



Clustered Systems

- Clustering allows two or more systems to share storage
- Provides high reliability
- *Asymmetric clustering*: one server runs the application or applications while other servers standby
- *Symmetric clustering*: all N hosts are running the application or applications



Real-Time Systems

- Often used as a control device in a dedicated application such as controlling scientific experiments, medical imaging systems, industrial control systems, and some display systems
- Well-defined fixed-time constraints
- Real-Time systems may be either *hard* or *soft* real-time





Real-Time Systems (Cont.)

- Hard real-time:
 - Secondary storage limited or absent, data stored in short term memory, or read-only memory (ROM)
 - Conflicts with time-sharing systems, not supported by general-purpose operating systems
- Soft real-time
 - Limited utility in industrial control of robotics
 - Integrate-able with time-share systems
 - Useful in applications (multimedia, virtual reality) requiring tight response times



Handheld Systems

- Personal Digital Assistants (PDAs)
- Cellular telephones
- Issues:
 - Limited memory
 - Slow processors
 - Small display screens





Migration of Operating-System Concepts and Features

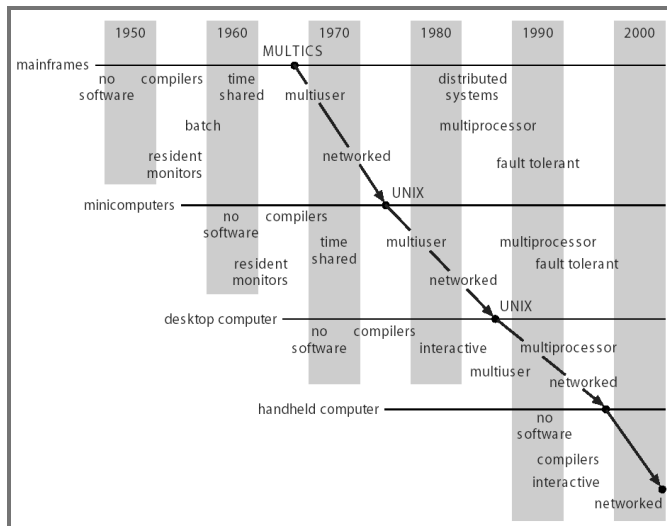

Computing Environments

- Traditional computing
 - PCs, Servers, limited remote access
- Web-Based Computing
 - Client-server and web services, convenient remote access, location-less servers
- Embedded Computing
 - Most computers (auto engine controllers, microwaves)
 - Very limited operating system features
 - Little or no user interface, remote access

